

www.wackergroup.com

| | |
|-----------|-----|
| 0154587en | 004 |
| 0706 | |

Generator

G 5.6A

GS 5.6A

OPERATOR'S MANUAL



DANGER
CARBON MONOXIDE

Using a generator indoors CAN KILL YOU IN MINUTES.

Generator exhaust contains carbon monoxide (CO). This is a poison you cannot see or smell. If you can smell the generator exhaust, you are breathing CO. But even if you cannot smell the exhaust, you could be breathing CO.

- NEVER use a generator inside homes, garages, crawlspaces, or other partly enclosed areas. Deadly levels of carbon monoxide can build up in these areas. Using a fan or opening windows and doors does NOT supply enough fresh air.
- ONLY use a generator outside and far away from windows, doors, and vents. These openings can pull in generator exhaust.

Even when you use a generator correctly, CO may leak into the home. ALWAYS use a battery-powered or battery-backup CO alarm in the home.

If you start to feel sick, dizzy, or weak after the generator has been running, move to fresh air RIGHT AWAY. See a doctor. You could have carbon monoxide poison.

| | |
|---|-----------|
| 1. Foreword | 3 |
| 2. Safety Information | 4 |
| 2.1 Laws Pertaining to Spark Arresters | 4 |
| 2.2 Operating Safety | 5 |
| 2.3 Operator Safety while using Internal Combustion Engines | 6 |
| 2.4 Service Safety | 7 |
| 2.5 Label Locations | 8 |
| 2.6 Safety and Operating Labels | 9 |
| 3. Technical Data | 12 |
| 3.1 Generator | 12 |
| 3.2 Engine | 13 |
| 4. Operation | 14 |
| 4.1 Determining Power Requirements | 14 |
| 4.2 Outdoor Installation | 15 |
| 4.3 Indoor Installation | 15 |
| 4.4 Recommended Battery (GS 5.6A only) | 15 |
| 4.5 Wheel Kit | 16 |
| 4.6 Generator Derating | 17 |
| 4.7 Grounding the Generator | 18 |
| 4.8 Use of Extension Cords | 19 |
| 4.9 Control Panel | 20 |
| 4.10 Ground Fault Interrupt (GFI) | 21 |
| 4.11 Twist Lock Receptacles | 21 |
| 4.12 Engine Switch | 21 |
| 4.13 Engine Auto Idle | 22 |
| 4.14 Engine Speed | 22 |
| 4.15 Voltage Selection | 23 |
| 4.16 Before Starting | 24 |
| 4.17 To Start | 25 |
| 4.18 To Stop | 26 |
| 4.19 Operating Heavy Loads | 26 |

| | | |
|-----------|-------------------------------------|-----------|
| 5. | Maintenance | 27 |
| 5.1 | Engine Maintenance | 27 |
| 5.2 | Periodic Maintenance Schedule | 27 |
| 5.3 | Engine Oil | 28 |
| 5.4 | Air Cleaner | 29 |
| 5.5 | Spark Plug | 30 |
| 5.6 | Cleaning the Sediment Cup | 31 |
| 5.7 | Carburetor Adjustment | 31 |
| 5.8 | Auto Idle Speed | 32 |
| 5.9 | Engine Speed | 33 |
| 5.10 | Storage | 34 |
| 5.11 | Transport | 34 |
| 5.12 | Troubleshooting | 35 |
| 5.13 | Wire Colors | 35 |
| 5.14 | Electrical Schematic | 36 |
| 5.15 | Engine Schematic | 37 |

CALIFORNIA

Proposition 65 Warning:



Engine exhaust, some of its constituents, and certain vehicle components, contain or emit chemicals known to the State of California to cause cancer and birth defects or other reproductive harm.

1. Foreword

This manual provides information and procedures to safely operate and maintain this Wacker model. For your own safety and protection from injury, carefully read, understand and observe the safety instructions described in this manual.

Keep this manual or a copy of it with the machine. If you lose this manual or need an additional copy, please contact Wacker Corporation. This machine is built with user safety in mind; however, it can present hazards if improperly operated and serviced. Follow operating instructions carefully! If you have questions about operating or servicing this equipment, please contact Wacker Corporation.

The information contained in this manual was based on machines in production at the time of publication. Wacker Corporation reserves the right to change any portion of this information without notice.

All rights, especially copying and distribution rights, are reserved.

Copyright 2006 by Wacker Corporation.

No part of this publication may be reproduced in any form or by any means, electronic or mechanical, including photocopying, without express written permission from Wacker Corporation.

Any type of reproduction or distribution not authorized by Wacker Corporation represents an infringement of valid copyrights and will be prosecuted. We expressly reserve the right to make technical modifications, even without due notice, which aim at improving our machines or their safety standards.

2. Safety Information

This manual contains DANGER, WARNING, CAUTION, and NOTE callouts which must be followed to reduce the possibility of personal injury, damage to the equipment, or improper service.



This is the safety alert symbol. It is used to alert you to potential personal injury hazards. Obey all safety messages that follow this symbol to avoid possible injury or death.



DANGER

DANGER indicates a hazardous situation which, if not avoided, will result in death or serious injury.



WARNING

WARNING indicates a hazardous situation which, if not avoided, could result in death or serious injury.



CAUTION

CAUTION indicates a hazardous situation which, if not avoided, could result in minor or moderate injury.

CAUTION: Used without the safety alert symbol, CAUTION indicates a potentially hazardous situation which, if not avoided, may result in property damage.

Note: *Contains additional information important to a procedure.*

2.1 Laws Pertaining to Spark Arresters

Notice: State Health Safety Codes and Public Resources Codes specify that in certain locations spark arresters be used on internal combustion engines that use hydrocarbon fuels. A spark arrester is a device designed to prevent accidental discharge of sparks or flames from the engine exhaust. Spark arresters are qualified and rated by the United States Forest Service for this purpose.

In order to comply with local laws regarding spark arresters, consult the engine distributor or the local Health and Safety Administrator.

2.2 Operating Safety



BACKFEED FROM THE GENERATOR INTO THE PUBLIC POWER DISTRIBUTION SYSTEM CAN CAUSE SERIOUS INJURY OR DEATH TO UTILITY WORKERS!

Improper connection of generator to a building's electrical system can allow electrical current from the generator to backfeed into utility lines. This may result in electrocution of utility workers, fire, or explosion. Connections to a building's electrical system must be made by a qualified electrician and comply with all applicable laws and electrical codes.

If connected to a building's electrical system the generator must meet the power, voltage, and frequency requirements of the equipment in the building. Differences in power, voltage, and frequency requirements may exist and improper connection may lead to equipment damage, fire, and personal injury or death.



Familiarity and proper training are required for the safe operation of equipment. Equipment operated improperly or by untrained personnel can be dangerous. Read the operating instructions contained in both this manual and the engine manual and familiarize yourself with the location and proper use of all controls. Inexperienced operators should receive instruction from someone familiar with the equipment before being allowed to operate the machine.

- 2.2.1 NEVER operate the generator when open containers of fuel, paint, or other flammable liquids are near.
- 2.2.2 NEVER operate the generator, or tools attached to the generator, with wet hands.
- 2.2.3 NEVER use worn electrical cords. Severe electrical shock and equipment damage may result.
- 2.2.4 NEVER run the electrical cords under the generator, or over vibrating or hot parts.
- 2.2.5 NEVER enclose or cover the generator when it is in use or when it is hot.
- 2.2.6 NEVER overload the generator. The total amperage of the tools and equipment attached to the generator must not exceed the load rating of the generator.
- 2.2.7 NEVER operate the machine in snow, rain, or standing water.
- 2.2.8 NEVER allow untrained personnel to operate or service the generator. The generator set should be set up by a trained electrician.
- 2.2.9 ALWAYS store the equipment properly when it is not being used. Equipment should be stored in a clean, dry location out of the reach of children.

- 2.2.10 ALWAYS be sure the machine is on a firm, level surface and will not tip, roll, slide, or fall while operating.
- 2.2.11 ALWAYS transport the generator in an upright position.
- 2.2.12 ALWAYS keep the machine at least one meter (three feet) away from structures, buildings, and other equipment during use.
- 2.2.13 ALWAYS keep the area immediately surrounding and underneath the machine clean, neat, and free of debris and combustible materials. Make sure that the area overhead is clear of debris that could fall onto or into the machine or exhaust compartment.
- 2.2.14 ALWAYS remove all tools, cords, and other loose items from the generator before starting it.
- 2.2.15 ALWAYS make certain the machine is well-grounded and securely fastened to a good earthen ground per national and local regulations.

2.3 Operator Safety while using Internal Combustion Engines



DANGER

Internal combustion engines present special hazards during operation and fueling. Read and follow the warning instructions in the engine owner's manual and the safety guidelines below. Failure to follow the warnings and safety guidelines could result in severe injury or death.

- 2.3.1 DO NOT run the machine indoors or in an enclosed area such as a deep trench unless adequate ventilation, through such items as exhaust fans or hoses, is provided. Exhaust gas from the engine contains poisonous carbon monoxide gas; exposure to carbon monoxide can cause loss of consciousness and may lead to death.
- 2.3.2 DO NOT smoke while operating the machine.
- 2.3.3 DO NOT smoke when refueling the engine.
- 2.3.4 DO NOT refuel a hot or running engine.
- 2.3.5 DO NOT refuel the engine near an open flame.
- 2.3.6 DO NOT spill fuel when refueling the engine.
- 2.3.7 DO NOT run the engine near open flames.
- 2.3.8 DO NOT start the engine if fuel has spilled or a fuel odor is present. Move the generator away from the spill and wipe the generator dry before starting.
- 2.3.9 ALWAYS refill the fuel tank in a well-ventilated area.
- 2.3.10 ALWAYS replace the fuel tank cap after refueling.
- 2.3.11 ALWAYS check the fuel lines and the fuel tank for leaks and cracks before starting the engine. Do not run the machine if fuel leaks are present or the fuel lines are loose.

2.4 Service Safety



Poorly maintained equipment can become a safety hazard! In order for the equipment to operate safely and properly over a long period of time, periodic maintenance and occasional repairs are necessary. If the generator is experiencing problems or is being serviced, attach a “DO NOT START” sign to the control panel to notify other people of its condition.

- 2.4.1 DO NOT use gasoline or other types of fuels or flammable solvents to clean parts, especially in enclosed areas. Fumes from fuels and solvents can become explosive.
- 2.4.2 DO NOT attempt to clean or service the machine while it is running.
- 2.4.3 DO NOT modify the equipment without the express written approval of the manufacturer.
- 2.4.4 DO NOT allow water to accumulate around the base of the machine. If water is present, move the machine and allow the machine to dry before servicing.
- 2.4.5 DO NOT service the machine if your clothing or skin is wet.
- 2.4.6 DO NOT allow untrained personnel to service this equipment. Only trained electrical technicians should be allowed to service the electrical components of this equipment.
- 2.4.7 ALWAYS keep the machine clean and labels legible. Replace all missing and hard-to-read labels. Labels provide important operating instructions and warn of dangers and hazards.
- 2.4.8 ALWAYS replace the safety devices and guards after repairs and maintenance.
- 2.4.9 ALWAYS let the engine cool before transporting or servicing it.
- 2.4.10 ALWAYS keep hands, feet, and loose clothing away from the moving parts on the generator and engine.
- 2.4.11 ALWAYS turn the engine off before servicing the machine. If the engine has electric start, disconnect the negative terminal on the battery before servicing the machine.
- 2.4.12 ALWAYS keep the fuel lines in good condition and properly connected. Leaking fuel and fumes are extremely explosive.



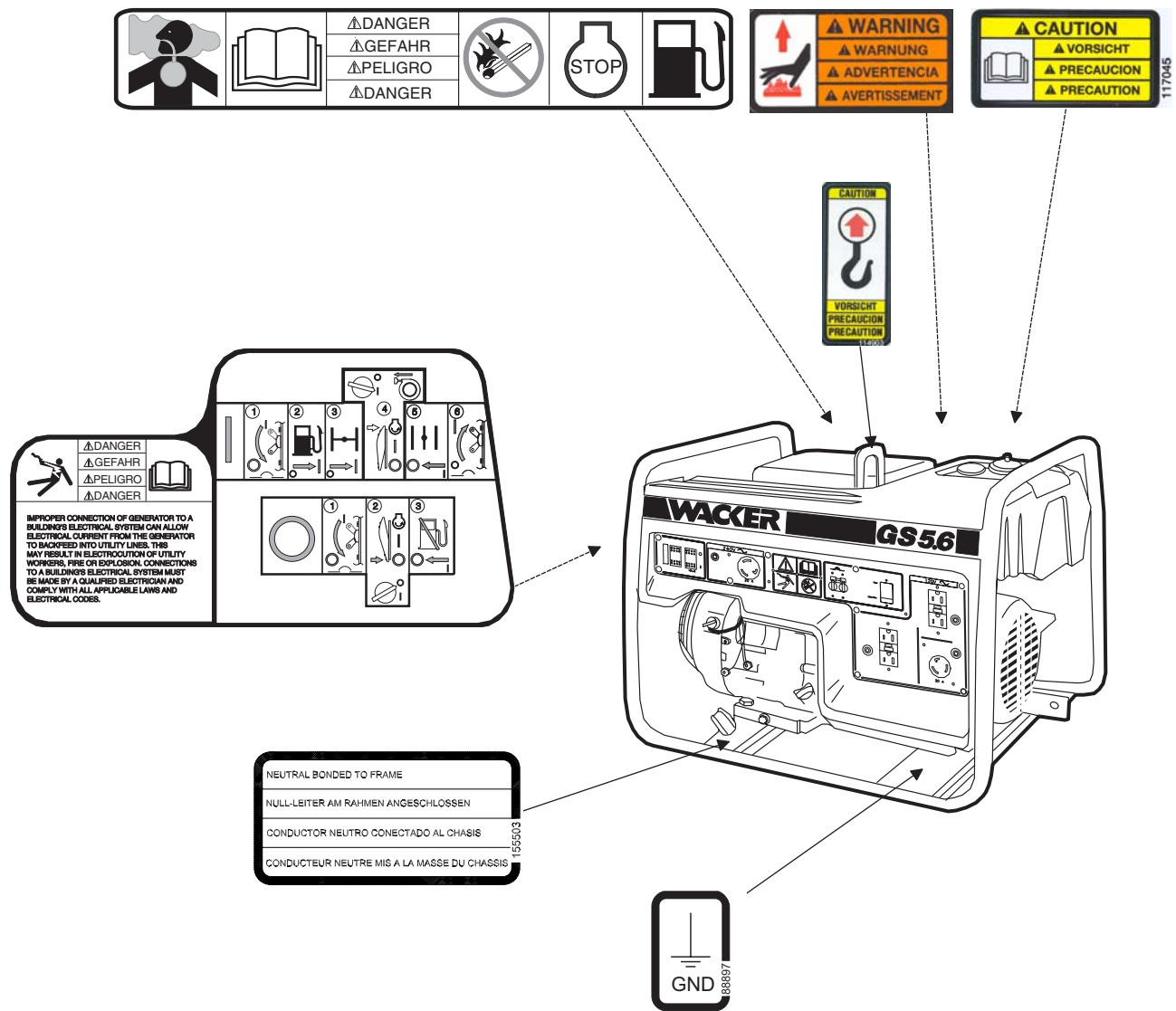

2.5 Label Locations



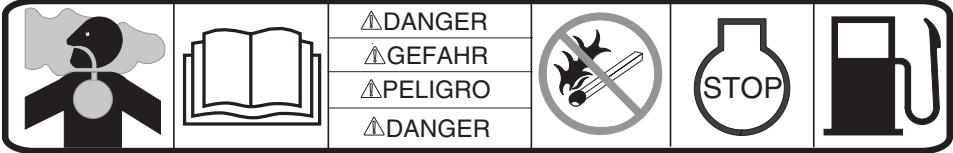

wc_gr000543

2.6 Safety and Operating Labels

Wacker machines use international pictorial labels where needed. These labels are described below:

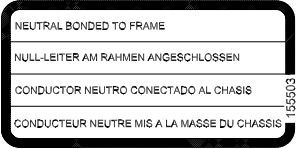
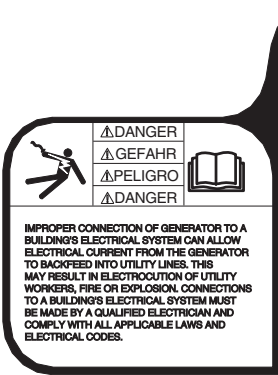
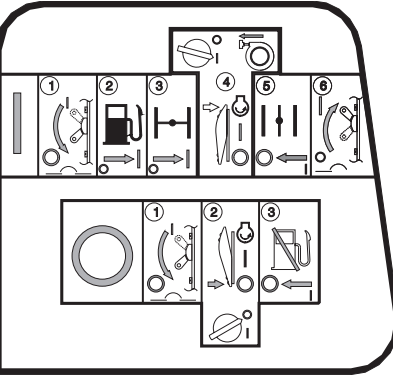
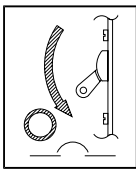
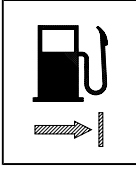
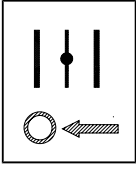
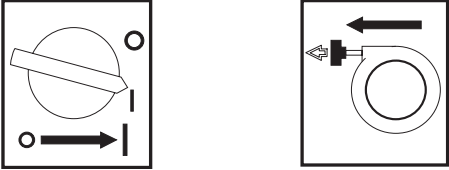
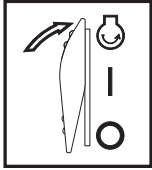
| Label | Meaning |
|---|---|
|  | <p>DANGER! Engines emit carbon monoxide; operate only in well-ventilated area. Read the Operator's Manual. No sparks, flames, or burning objects near the machine. Shut off the engine before refueling.</p> |
|  | <p>WARNING! Hot surface!</p> |
|  | <p>CAUTION! Read and understand the supplied Operator's Manuals before operating this machine. Failure to do so increases the risk of injury to yourself or others.</p> |
|  | <p>CAUTION! Lifting point</p> |
|  | <p>Electrical ground</p> |

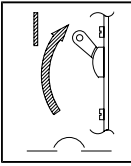
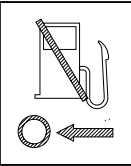
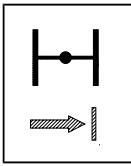
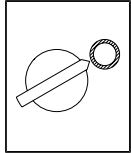
| Label | Meaning |
|---|--|
|  | <p>Neutral bonded to frame.</p> |
|  |  |
|  | <p>Open main circuit breaker.</p> |
|  | <p>Open the fuel flow valve.</p> |
|  | <p>Open the choke.</p> |
|  | <p>Push or turn engine switch to ON position. Pull the rewind starter.</p> |
|  | <p>Press engine crank switch to "CRANK" position.</p> |

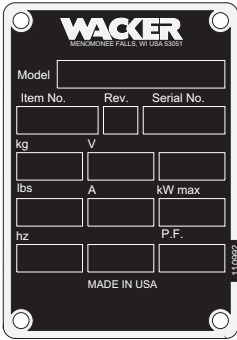
| Label | Meaning |
|--|---|
|  | <p>Close main circuit breaker.</p> |
|  | <p>Close the fuel flow valve.</p> |
|  | <p>Close the choke.</p> |
|  | <p>Push or turn engine switch to OFF position.</p> |
|  | <p>Press engine crank switch to "OFF" position.</p> |
|  | <p>A nameplate listing the model number, item number, revision number, and serial number is attached to each unit. Please record the information found on this plate so it will be available should the nameplate become lost or damaged. When ordering parts or requesting service information, you will always be asked to specify the model number, item number, revision number, and serial number of the unit.</p> |
| <div style="border: 1px solid black; padding: 5px; width: fit-content;"> <p>U.S. PAT. Nos.:</p> <p>OTHER U.S. AND FOREIGN PATENTS PENDING</p> </div> | <p>This machine may be covered by one or more patents.</p> |

3. Technical Data

3.1 Generator

| Item No. | | G 5.6A 0007190, 0009431 | GS 5.6A 0007191 |
|-----------------------|----------------|--|---------------------------|
| Generator | | | |
| Maximum Output | W | 5600 | |
| Continuous Output | W | 5350 | |
| Type | | Dual voltage, single phase, Auto voltage regulator system | |
| AC Voltages Available | volts phase | 120 / 240 1ø | |
| Frequency | Hz | 60 | |
| Power Factor | | 1.0 | |
| AC receptacles: | | | |
| 120V GFI duplex | amp | 20 | |
| 120V GFI duplex | amp | 20 | |
| 120V twist lock | amp | 30 | |
| 240V twist lock | amp | 20 | |
| Main Circuit Breaker | amp | 48 (2-pole, 24 amp each pole) | |
| L x W x H | mm (in.) | 685 x 585 x 530 (27 x 23 x 21) | |
| Weight (dry) | Kg (lbs.) | 76 (168) | 79 (175) |

3.2 Engine

| Item No. | G 5.6A 0007190, 0009431 | | GS 5.6A 0007191 | |
|--------------------------|--|---|--|--|
| Engine | | | | |
| Engine Type | Single cylinder, 4-cycle, air-cooled, gasoline engine | | | |
| Engine Make | Honda | | | |
| Engine Model | GX 340 K1 | | | |
| Rated Power | kW (Hp) | 8.2 (11) | | |
| Spark Plug | BPR6ES / W20EPR-U | | | |
| Electrode Gap | mm (in.) | 0.7 - 0.8 (0.028 - 0.031) | | |
| Engine Speed - full load | rpm | 3600 ± 100 | | |
| Engine Speed - no load | rpm | 3700 ± 100 | | |
| Auto Idle Speed | rpm | 2200 ± 50 | | |
| Air Cleaner | type | Dry type with oil-wetted foam pre-cleaner | | |
| Battery | type | N/A | Y50-N18L-A or C50-N18L-A 12V - 20 Amp-hour 8- ¹ / ₈ x 3- ⁹ / ₁₆ x 6- ⁷ / ₁₆ | |
| | V/capacity Size (in.) | | | |
| Engine Lubrication | oil grade | SAE 10W30 service class SF, SE, SD or SC | | |
| Engine Oil Capacity | l (qts.) | 1.1 (1.2) | | |
| Fuel | type | Regular unleaded gasoline | | |
| Fuel Tank Capacity | l (gal.) | 19.5 (5.2) | | |
| Fuel Consumption | l (qts.)/hr. | 3.6 (3.8) | | |
| Running Time - full load | hrs. | 5.4 | | |

4. Operation

4.1 Determining Power Requirements

This generator is designed to operate single-phase, 60 Hz appliances running at 120 VAC or 240 VAC. Check the nameplate or label provided on tools and appliances to make sure their power requirements match the power output of the generator.

Some appliances and tools require a surge of current when starting. This means that the amount of power needed to initially start the equipment is larger than the power required to keep it running. The generator must be capable of supplying this “surge” current. Other types of appliances require more power than is actually stated on their nameplate.

The information in “Approximate Starting Power Requirements” is offered only as a general guideline to help you in determining power requirements for different types of equipment. Check with your nearest Wacker Dealer, or contact the manufacturer or dealer of the tool or appliance, with questions regarding its power requirements.

CAUTION: If a tool or appliance does not reach full speed within a few seconds when switched on, turn it off immediately to avoid damage.

Approximate Starting Power Requirements

- Incandescent lights and appliances such as irons and hot plates, which use a resistive-type heating element, require the same wattage to start and run as is stated on their nameplates.
- Fluorescent and mercury lamps require 1.2–2 times their stated wattage to start.
- Electrical motors and many types of electrical tools often require a large starting current. The amount of starting current depends on the type of motor and its use.
- Most electrical tools require 1.2–3 times their stated wattage for starting.
- Loads such as submersible pumps and air compressors require a very large force to start. They need as much as 3–5 times the wattage stated on the nameplate in order to start.

If the wattage is not given for a particular tool or appliance, it can be calculated by multiplying its voltage and amperage requirements:

Single Phase: VOLTS x AMPS = WATTS

Three Phase: VOLTS x AMPS x 1.732 x 0.8 = WATTS

4.2 Outdoor Installation

Place the generator in an area where it will not be exposed to rain, snow, or direct sunlight. Make sure it is positioned on firm, level ground, so it will not slide or shift. Position the engine exhaust away from areas where people may be present.

If operating the generator inside a tunnel or deep trench, make sure there is adequate ventilation. Precautions similar to those required when operating indoors may be necessary.

The surrounding area must be free from water and moisture. All components must be protected from excessive moisture.

4.3 Indoor Installation

If the generator must be installed indoors, adequate ventilation or exhaust hoses must be provided. When venting exhaust fumes, make sure the exhaust piping is large enough to prevent excessive back pressure to the engine. Back pressure reduces engine efficiency and may cause the engine to overheat.



Exhaust gas from the engine contains poisonous carbon monoxide gas; exposure to carbon monoxide can cause loss of consciousness and may lead to death. Never run the generator indoors or in an enclosed area unless adequate ventilation, through such items as exhaust hoses or fans, is provided.

When installed indoors, steps to prevent fire and explosion such as providing a good, earthen ground, removing all flammable materials near the generator, and using only electrical cables in good condition, must be observed. See *Operating Safety*.

4.4 Recommended Battery (GS 5.6A only)

This generator is shipped without a battery. The recommended battery to be used is:

| | |
|--------------|--|
| Battery Type | 50-N18L-A |
| Voltage | 12 V |
| Capacity | 20 A/h |
| L x W x H | 206 x 90 x 164 mm (8-1/8 x 3-9/16 x 6-7/16 in.) |

4.5 Wheel Kit

See Graphic: *wc_gr001577*

Wheel kit (Part No. 0157176) is a standard item on Item Number 0009431 and 0620008 only. Available as an option on all other models.

- 4.5.1 Align grooves **(a)** on axle **(b)** with U-bolts **(c)** and secure to cross-member of generator.
- 4.5.2 Assemble lock washer **(d)** and nuts to U-bolts. Torque nuts to 8.1 Nm (6 ft.lbs.).
- 4.5.3 Insert caps **(e)** on U-bolts.
- 4.5.4 Assemble washers **(f)** next to retaining clips **(g)**.
- 4.5.5 Attach tires **(h)** with washers **(i)** next to wheels, insert cotter pins **(j)** into holes and separate legs of pins.
- 4.5.6 Align holes found in handles **(k)** to holes of brackets **(l)** on frame.
- 4.5.7 Insert screws **(m)** through washers **(n)** then through holes of handles and brackets on frame.
- 4.5.8 Attach washers **(o)** and nuts **(p)** onto screws and tighten. Torque nuts to 25 Nm (18 ft.lbs.).

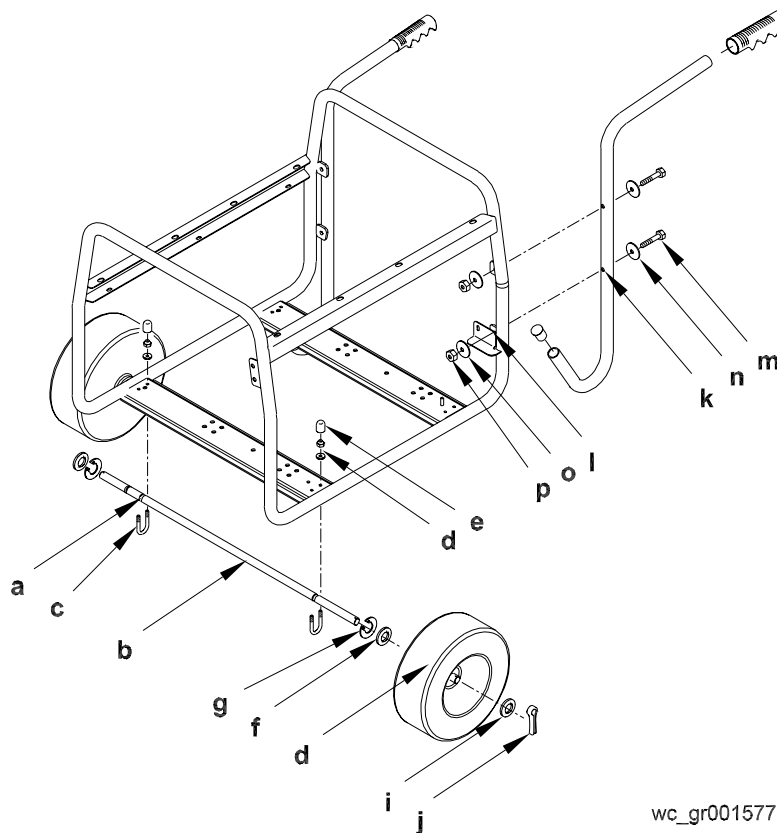

wc_gr001577

4.6 Generator Derating

All generators are subject to derating for altitude and temperature. Internal combustion engines, unless modified, run less efficiently at higher altitudes due to the reduction of air pressure. This translates into a lack of power and thus reduction in generator output. Temperature affects both engine and generator performance. As temperature increases, an engine will run less efficiently and more resistance will be found in electrical components. Therefore, as the temperature increases, the output of the generator decreases. Altitude also affects the cooling capacity of air—the higher the altitude the less dense the air is and thus the lower its ability to transfer heat.

For every increase in altitude of 500 m (1650 ft.) above 1000 m (3300 ft.), the output of the generator will be reduced by 3%. For every increase of 5° C (9° F) in ambient temperature above 40° C (104° F), the output of the generator will be reduced by 3%. Use the tables shown for altitude and temperature deration factors. It may be necessary to consider both altitude and ambient temperature deration factors to determine true generator output.

| Ambient Temp. °C (°F) | Derate | Factor |
|--------------------------|--------|--------|
| 45 (113) | 3 % | 0.97 |
| 50 (122) | 6 % | 0.94 |
| 55 (131) | 9 % | 0.91 |
| 60 (140) | 12 % | 0.88 |

| Altitude m (ft.) | Derate | Factor |
|---------------------|--------|--------|
| 1500 (4900) | 3 % | 0.97 |
| 2000 (6600) | 6 % | 0.94 |
| 2500 (8200) | 9 % | 0.91 |
| 3000 (9900) | 12 % | 0.88 |
| 3500 (11500) | 15 % | 0.85 |
| 4000 (13100) | 18 % | 0.82 |

4.7 Grounding the Generator

See Graphic: *wc_gr000544*

A ground connection (**a**) is located on the generator frame. For proper operating safety, this ground terminal must be connected to a good ground source. This ground connection must comply with National Electrical Code standards, and state and local regulations.

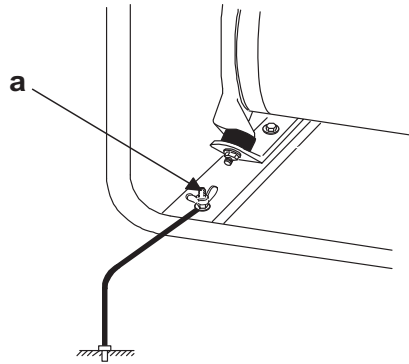

wc_gr000544

4.8 Use of Extension Cords

When a long extension cord is used to connect an appliance or tool to the generator, a voltage loss occurs—the longer the cord, the greater the voltage loss. This results in less voltage being supplied to the appliance or tool and increases the amount of current draw or reduces performance. A heavier cord with a larger wire size will reduce the voltage loss.



WARNING

Damaged extension cords can cause electrical shock, resulting in serious injury or death. **DO NOT** use worn, bare, or frayed cords. Replace damaged cords immediately.

Use the chart below as a guide for selecting proper cable size.

| Current (Amps) | Load in Watts | | Maximum Cable Length in Feet | | | |
|-------------------|---------------|------|------------------------------|-----|-----|-----|
| | 120V | 240V | #10 | #12 | #14 | #16 |
| 2.5 | 300 | 600 | 1000. | 600 | 375 | 250 |
| 5 | 600 | 1200 | 500 | 300 | 200 | 125 |
| 7.5 | 900 | 1800 | 350 | 200 | 125 | 100 |
| 10 | 1200 | 2400 | 250 | 150 | 100 | - |
| 15 | 1800 | 3600 | 150 | 100 | 65 | - |
| 20 | 2400 | 4800 | 125 | 75 | 50 | - |

Use only extension cords rated for outdoor use and equipped with a third-wire ground.

CAUTION: Operating equipment at low voltage can cause it to overheat.

4.9 Control Panel

See Graphic: wc_gr000545

Control Panel

| Ref. | Description | Ref. | Description |
|------|------------------------------|------|------------------------------|
| a | Engine Switch (GS 5.6A only) | f | GFI Duplex receptacle - 120V |
| b | Auto Idle Switch | g | GFI test button |
| c | Twist-lock receptacle - 240V | h | GFI reset button |
| d | Main Breaker - 48 amps | j | Twist-lock receptacle - 120V |
| e | Voltage Selector Switch | | |

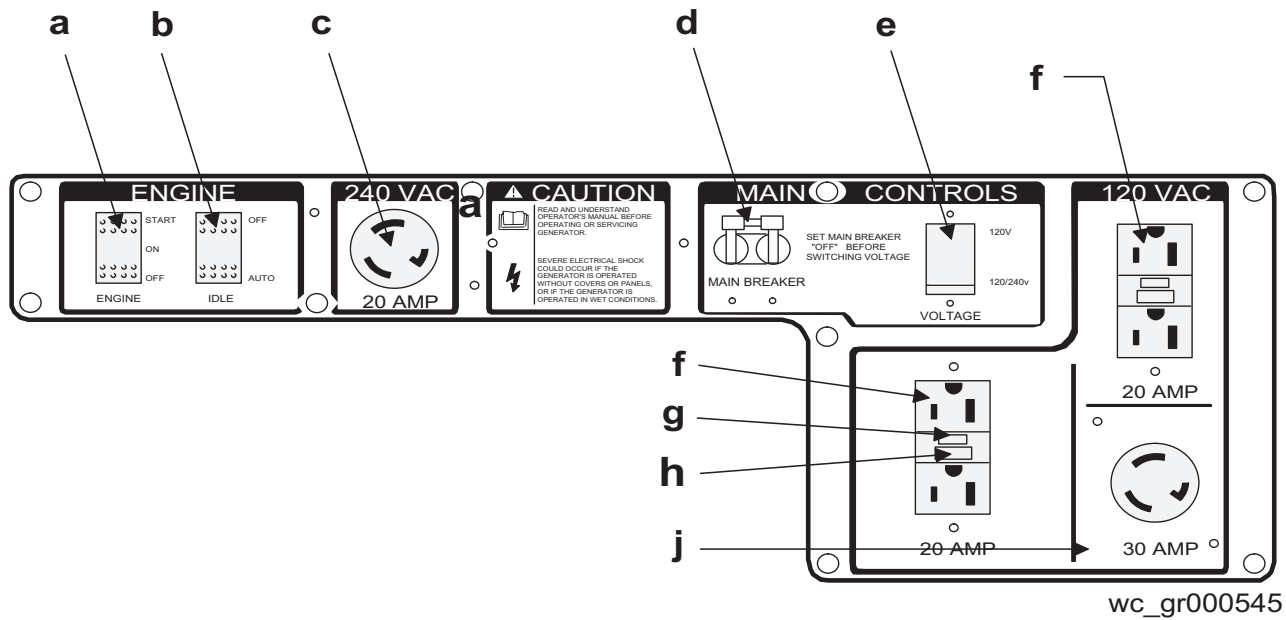

wc_gr000545

4.10 Ground Fault Interrupt (GFI)

See Graphic: *wc_gr000545*

The two 120V, 20 Amp receptacles **(f)** are protected by a ground fault circuit interrupt (GFI). The GFI shuts off the power to the receptacle when a ground fault occurs in the generator or to a piece of equipment attached to the generator.

The GFI should be tested for proper operation every time the generator is used.

To test GFI:

Start generator. Turn auto idle "OFF". Push TEST button **(h)** on receptacle in. The RESET button **(g)** will pop out. Power is now off at the receptacles. If the RESET button does not pop out, the GFI is not working. Do not run generator until the problem can be corrected. To restore power to receptacles, push the RESET button in.

If the RESET button pops out during operation, stop the generator and check generator and equipment for defects.

4.11 Twist Lock Receptacles

See Graphic: *wc_gr000545*

Twist-lock receptacles **(c, j)** are used at the 120V 30A and 120/240V 30A outlets. These receptacles are not protected by the GFI.

To attach a power cord to a twist-lock receptacle, insert the plug into the receptacle and turn it clockwise to lock it in place.

4.12 Engine Switch

See Graphic: *wc_gr000545*

GS 5.6A only:

The engine switch **(a)** completes the circuit to the engine's ignition system. The switch must be set to "START" and then held down to crank the starter motor and start the engine. When the switch is released it returns back to the "ON" position and must be kept in this position while the engine is running.

To stop engine, set switch to "OFF".

4.13 Engine Auto Idle

See Graphic: *wc_gr000545*

The auto idle switch **(b)** automatically reduces engine speed approximately 7 seconds after all appliances or tools attached to the generator have been turned off. The engine automatically returns to full speed when a tool or appliance is turned back on.

To turn the auto idle feature on, push the auto idle switch to "AUTO". The AUTO setting is recommended while the generator is running to minimize fuel consumption. To avoid extended engine warm-up periods, keep switch set to "OFF" when starting the engine and until the engine reaches operating temperature.

4.14 Engine Speed

Generators require a fixed engine speed to maintain the correct voltage. Engine speed is controlled by a governor which automatically adjusts to varying loads on the engine to maintain a constant speed. See *Technical Data*. There is no throttle control. Use the Auto Idle switch on the generator to control engine speed.

4.15 Voltage Selection

See Graphic: *wc_gr000546*

The voltage selector switch (**a**) allows the generator to operate in either single (120V) or dual voltage (120/240V) mode.

In single voltage mode only the 120V twist-lock and duplex receptacles are powered. The full rated power of the generator is shared between the three receptacles.

In dual voltage mode both the 120V and 240V receptacles are powered; however, only half the rated power (23 amps) is available at the 120V duplex receptacles and the other half at the 120V twist-lock receptacle. Full power is available at the 240V twist-lock receptacle.

CAUTION: NEVER switch the voltage selector switch with the main breaker on! This can cause arcing and can damage the generator. Turn all tools and appliances off and place main breaker in the "OFF" position (O) before changing voltage switch position.

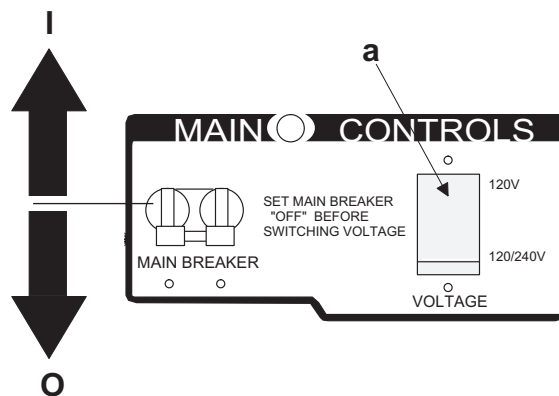

wc_gr000546

4.16 Before Starting

- 4.16.1 Read and understand the safety and operating labels and instructions at the beginning of this manual
- 4.16.2 Inspect the generator for any signs of damage which may affect operation or pose a safety hazard.
- 4.16.3 Check:
- oil level in engine
 - fuel level
 - condition of air cleaner
 - tightness of external fasteners
 - condition of fuel lines.
- Note:** *The engine is equipped with an oil alert system. If the oil level in the engine drops too low, the engine will not start.*
- 4.16.4 Fill the fuel tank with fresh, regular, unleaded grade gasoline. DO NOT use an oil/gas mixture. The use of gasohol or any fuel containing more than 10% ethanol is not recommended. Consult the engine owner's manual for complete fuel specifications.

4.17 To Start

See Graphic: *wc_gr000547*

Before starting, be sure you read and understand all the safety and operating instructions in this manual.

- 4.17.1 Disconnect all loads from the generator and place the main circuit breaker switch in the "OFF" (open) position. **(a1)**.
- 4.17.2 Set the Auto Idle Switch to "OFF" **(c)**.
- 4.17.3 Open the fuel valve **(d1)**.

Note: *If the engine is cold, move the choke lever to the closed position (e1). If the engine is warm, set the choke to the open position (e2).*

- 4.17.4 On recoil start engines, turn the engine switch to "ON" **(f1)** and pull the starter rope **(g)**.
- 4.17.5 On electric start engines, press the engine switch to "START" **(b1)** and hold it there until the engine starts. Release the switch after the engine starts.

CAUTION: DO NOT run the starter motor more than 5 seconds at a time or starter motor damage may occur. If the engine fails to start, release the switch and wait 10 seconds to let the starter motor cool before trying again.

Note: *If the oil level in the engine is low, the engine will not start. If this happens, check the oil level and add oil as needed.*

- 4.17.6 As the engine warms up, move the choke lever to the OPEN position **(e2)**.
- 4.17.7 Allow the engine to warm up for a few minutes before placing the main breaker in the "ON" (closed) position **(a2)** and attaching loads.

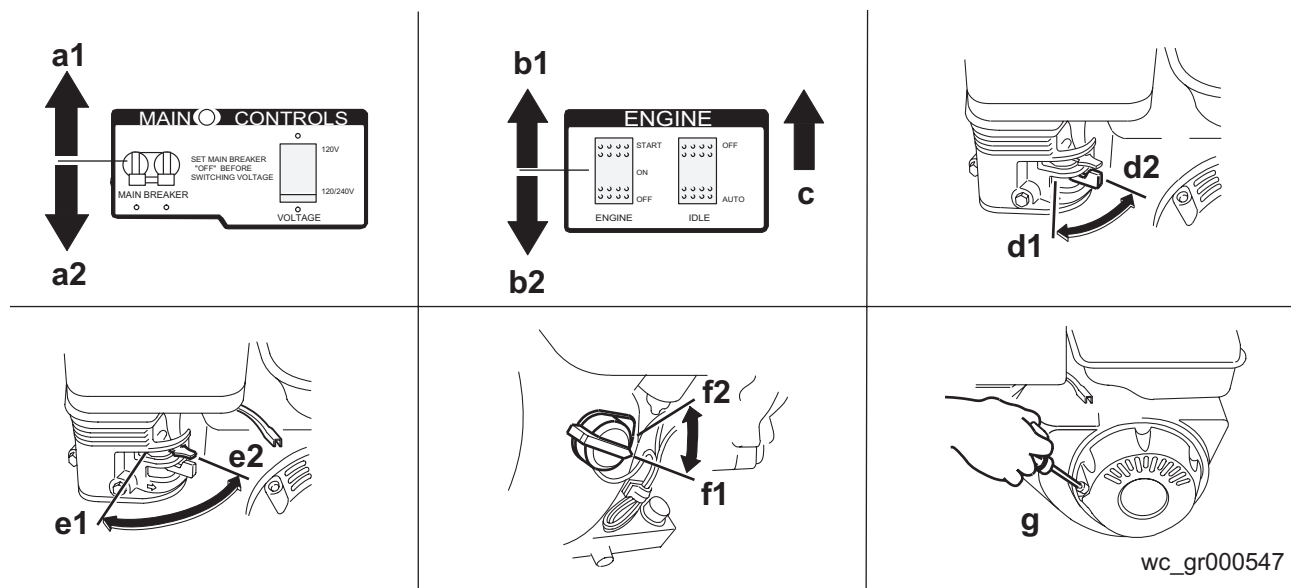

4.18 To Stop

See Graphic: *wc_gr000547*

- 4.18.1 Turn off and disconnect all tools and appliances attached to the generator.
- 4.18.2 Place the main circuit breaker in the OFF position **(a2)**.
- 4.18.3 Turn the engine switch to “OFF” **(b2)**.
- 4.18.4 Close the fuel valve **(d2)**.

Note: *To stop the engine quickly in an emergency, turn or press the engine switch to “OFF” (b2).*

4.19 Operating Heavy Loads

Limit operations requiring the maximum rated output of 5600 W to 20–30 minutes. For continuous operation do not exceed the continuous rated output of 5000 W.

CAUTION: DO NOT exceed the current limit specified on the control panel for any receptacle.

5. Maintenance

5.1 Engine Maintenance

The chart below lists basic machine and engine maintenance. Refer to the engine manufacturer's Operator's Manual for additional information on engine maintenance.

5.2 Periodic Maintenance Schedule

| | Daily before starting | After first 20 hrs. | Every 50 hrs. | Every 100 hrs. | Every 300 hrs. |
|--|-----------------------------|---------------------------|---------------------|----------------------|----------------------|
| Check the fuel level. | ■ | | | | |
| Check the engine oil level. | ■ | | | | |
| Inspect the air filter. Replace as needed. | ■ | | | | |
| Check external hardware. | ■ | | | | |
| Clean the air cleaner element.* | | | ■ | | |
| Inspect the shockmounts for damage. | | | | ■ | |
| Change the engine oil.* | | ■ | | ■ | |
| Clean the sediment cup or fuel strainer. | | | | ■ | |
| Check and clean the spark plug. | | | | ■ | |
| Check and adjust the valve clearance. | | | | | ■ |
| Clean the fuel tank.* | | | | | ■ |
| Check condition of the fuel line. Replace when necessary. | | | | | ■ |

*Service more frequently in dusty conditions.

5.3 Engine Oil

See Graphic: wc_gr000022

5.3.1 Drain the oil while the engine is still warm.

5.3.2 Remove the oil filler plug **(a)** and the drain plug **(b)** to drain the oil.

Note: *In the interests of environmental protection, place a plastic sheet and a container under the machine to collect any liquid that drains off. Dispose of this liquid in accordance with environmental protection legislation.*

5.3.3 Install the drain plug.

5.3.4 Fill the engine crankcase with the recommended oil up to the level of the plug opening **(c)**. See *Technical Data* for oil quantity and type.

5.3.5 Install the oil filler plug.

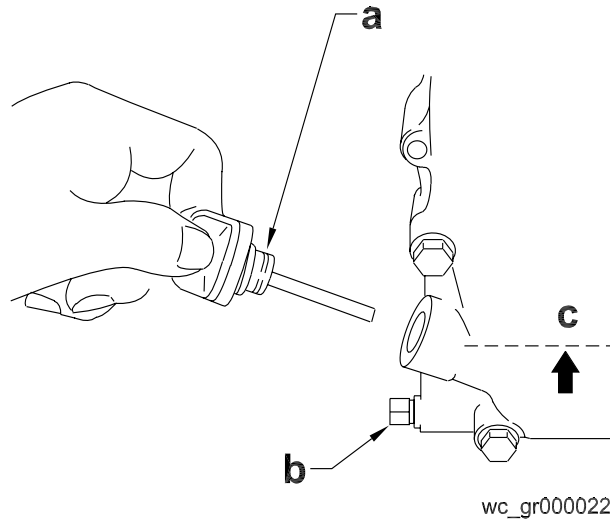

5.4 Air Cleaner

See Graphic: *wc_gr000025*

The engine is equipped with a dual element air cleaner. Service air cleaner frequently to prevent carburetor malfunction.

CAUTION: NEVER run engine without air cleaner. Severe engine damage will occur.



WARNING

NEVER use gasoline or other types of low flash point solvents for cleaning the air cleaner. A fire or explosion could result.

To service:

- 5.4.1 Remove air cleaner cover (**a**). Remove both elements and inspect them for holes or tears. Replace damaged elements.
- 5.4.2 Wash foam element (**b**) in solution of mild detergent and warm water. Rinse thoroughly in clean water. Allow element to dry thoroughly. Soak element in clean engine oil and squeeze out excess oil.
- 5.4.3 Tap paper element (**c**) lightly to remove excess dirt. Replace paper element if it appears heavily soiled.

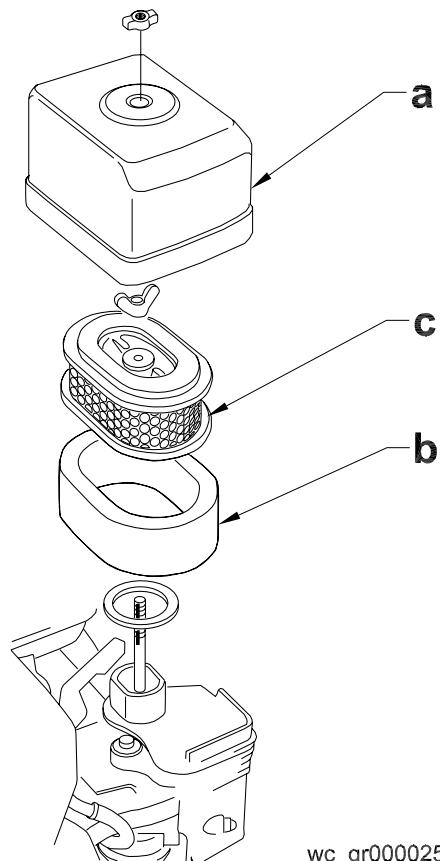

wc_gr000025

5.5 Spark Plug

See Graphic: *wc_gr000028*

Clean or replace the spark plug as needed to ensure proper operation. Refer to the engine owner's manual.



WARNING

The muffler becomes very hot during operation and remains hot for a while after stopping the engine. Do not touch the muffler while it is hot.

Note: Refer to the Technical Data for the recommended spark plug type and the electrode gap setting.

- 5.5.1 Remove the spark plug and inspect it.
- 5.5.2 Replace the spark plug if the insulator is cracked or chipped.
- 5.5.3 Clean the spark plug electrodes with a wire brush.
- 5.5.4 Set the electrode gap (**a**).
- 5.5.5 Tighten the spark plug securely.

CAUTION: A loose spark plug can become very hot and may cause engine damage.

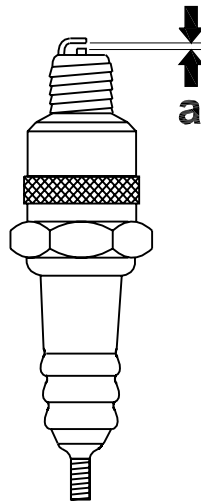

wc_gr000028

5.6 Cleaning the Sediment Cup

See Graphic: *wc_gr000029*

- 5.6.1 Turn the fuel valve off.
- 5.6.2 Remove the sediment cup (a) and the O-ring (b).
- 5.6.3 Wash both thoroughly in a nonflammable solvent. Dry and reinstall them.
- 5.6.4 Turn the fuel valve on and check for leaks.

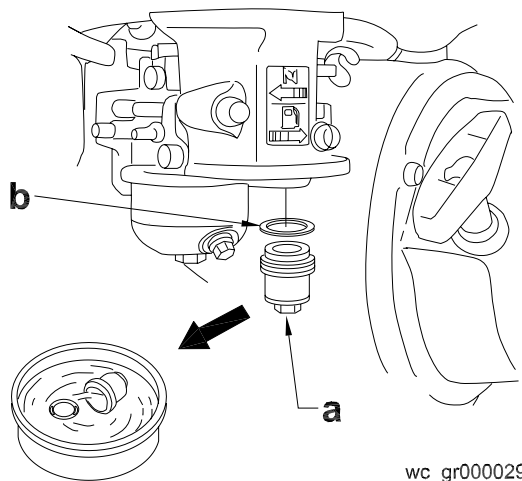

wc_gr000029

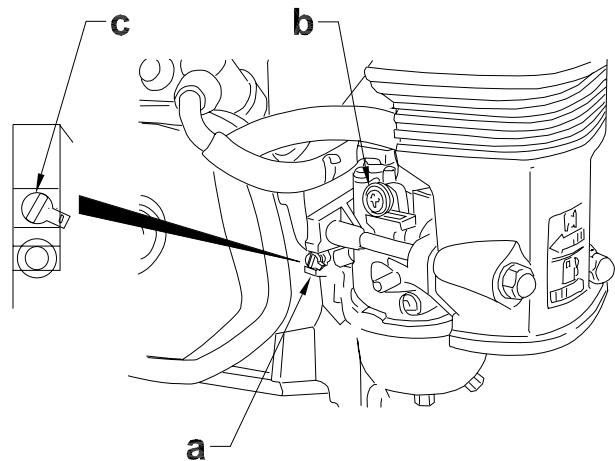

wc_gr000032

5.7 Carburetor Adjustment

See Graphic: *wc_gr000032*

- 5.7.1 Start the engine and allow it to warm up to operating temperature.
- 5.7.2 Set the pilot screw (a) two turns out. See *Note*.
- 5.7.3 With the engine idling, turn the pilot screw (a) in or out to the setting that produces the highest rpm.
- 5.7.4 After the pilot screw is adjusted, turn the throttle stop screw (b) to obtain the standard idle speed. See *Technical Data*.

Note: On some engines the pilot screw is fitted with a limiter cap (c) to prevent excessive enrichment of the air-fuel mixture in order to comply with emission regulations. The mixture is set at the factory and no adjustment should be necessary. Do not attempt to remove the limiter cap. The limiter cap cannot be removed without breaking the pilot screw.

5.8 Auto Idle Speed

See Graphic: wc_gr000548

- 5.8.1 Adjust pilot screw on carburetor as described above.
- 5.8.2 Loosen clamping screw **(b)** on auto idle magnet bracket.
- 5.8.3 Start engine and set auto idle switch to "Auto".
- 5.8.4 Turn magnet pin **(a)** in or out to adjust idle speed to 2200 ± 50 rpm.
Note: To avoid excessive vibration and to maintain adequate cooling ability, do not set engine auto idle speed lower than 2200 rpm.
- 5.8.5 Re-tighten clamping screw.

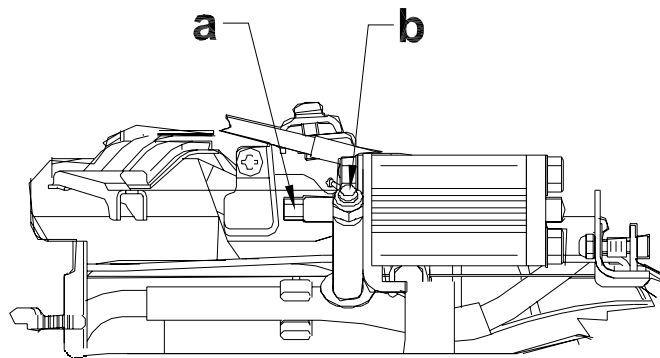

wc_gr000548

5.9 Engine Speed

See Graphic: *wc_gr000114*

Generators require a fixed engine speed to maintain the correct voltage. Engine speed is controlled by a governor which automatically adjusts to varying loads on the engine to maintain a constant speed of 3000 rpm. There is no throttle control.

To set the engine to the proper speed:

Turn the speed adjusting screw **(a)** in or out to obtain a no-load speed of 3000 rpm.

CAUTION: Setting the engine speed too high or too low may damage tools and other appliances attached to the generator.

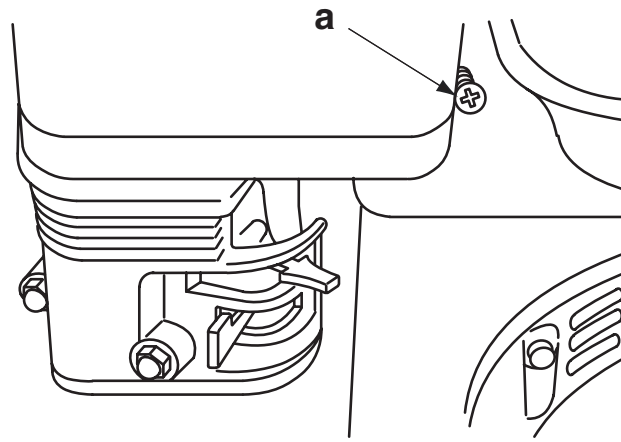

wc_gr000114

5.10 Storage

Before storing the generator for a long period of time:

- 5.10.1 Close the fuel valve and remove and empty the sediment cup or fuel strainer.
- 5.10.2 Disconnect the fuel line from the carburetor. Place open end of fuel line into a suitable container and open fuel valve to drain fuel from tank.



Gasoline is extremely flammable. Drain the fuel tank in a well-ventilated area. DO NOT drain the fuel tank in an area with flames or sparks.

- 5.10.3 Loosen the drain screw on the carburetor and drain any remaining fuel from the carburetor.
- 5.10.4 Change the engine oil.
- 5.10.5 Remove the spark plug and pour approximately 30 ml (1 ounce) of clean engine oil into the cylinder. Crank the engine a few turns to distribute the oil to the inside of the cylinder walls.
- 5.10.6 Pull the starter rope slowly until resistance is felt and leave the handle in this position. This ensures that the intake and exhaust valves are closed.
- 5.10.7 Store the generator in a clean, dry area.

5.11 Transport



Let the engine cool before transporting the generator or storing indoors, to avoid burns or fire hazards.

When transporting the generator:

- 5.11.1 Turn the engine fuel valve to the OFF position.
- 5.11.2 Position the generator level to prevent fuel from spilling.
- 5.11.3 Secure the generator by tying it down with a suitable rope.



When transporting the machine by hand, be sure to employ manpower commensurate with the weight of the machine. To avoid back injury when lifting the machine, bend the knees to pick it up rather than bending your back only.

5.12 Troubleshooting

| Problem / Symptom | Reason / Remedy |
|--|--|
| If engine doesn't start, check that: | <ul style="list-style-type: none"> • Engine switch is on "Start". • Fuel valves under fuel tank and on engine are open. • Fuel tank has fuel. • Choke lever is in correct position. Choke should be closed when starting a cold engine. • All loads are disconnected from generator. • Spark plug is in good condition. • Spark plug cap is tight. • Engine oil level is adequate. |
| If engine starts but there is no power at receptacles, check that: | <ul style="list-style-type: none"> • Circuit breaker is closed. • Connector from generator to control panel is tight. |
| If engine starts but runs erratically, check that: | <ul style="list-style-type: none"> • Hose routing from the fuel tank to the engine is correct. For proper operation, the hose must run through the bushing in the lifting bracket. Refer to the Parts Book for illustration. |

5.13 Wire Colors

| Wire Colors | | | | | | | |
|-------------|-------|---|--------|----|--------|----|------------|
| B | Black | R | Red | Y | Yellow | Or | Orange |
| G | Green | T | Tan | Br | Brown | Pr | Purple |
| L | Blue | V | Violet | Cl | Clear | Sh | Shield |
| P | Pink | W | White | Gr | Gray | LL | Light blue |

5.14 Electrical Schematic

See Graphic: wc_gr000556

| Ref. | Description | Ref. | Description | Ref. | Description |
|------|-------------|------|-------------|------|-------------|
| A | Generator | B | Control Box | C | Engine |

| Ref. | Description | Ref. | Description |
|------|-----------------------------|------|-------------------|
| 1. | Main Stator Winding | 7. | Auto Idle |
| 2. | Automatic Voltage Regulator | 8. | 1 Amp Fuse |
| 3. | Rotor Winding | 9. | Auto Idle Switch |
| 4. | Main Stator Winding | 10. | 120/240V 30A Kit* |
| 5. | Auxiliary Stator Winding | 11. | Electromagnet |
| 6. | Choke | | |

*W/B (Extra wire included in kit. Terminate at 120V 30A receptacle.)

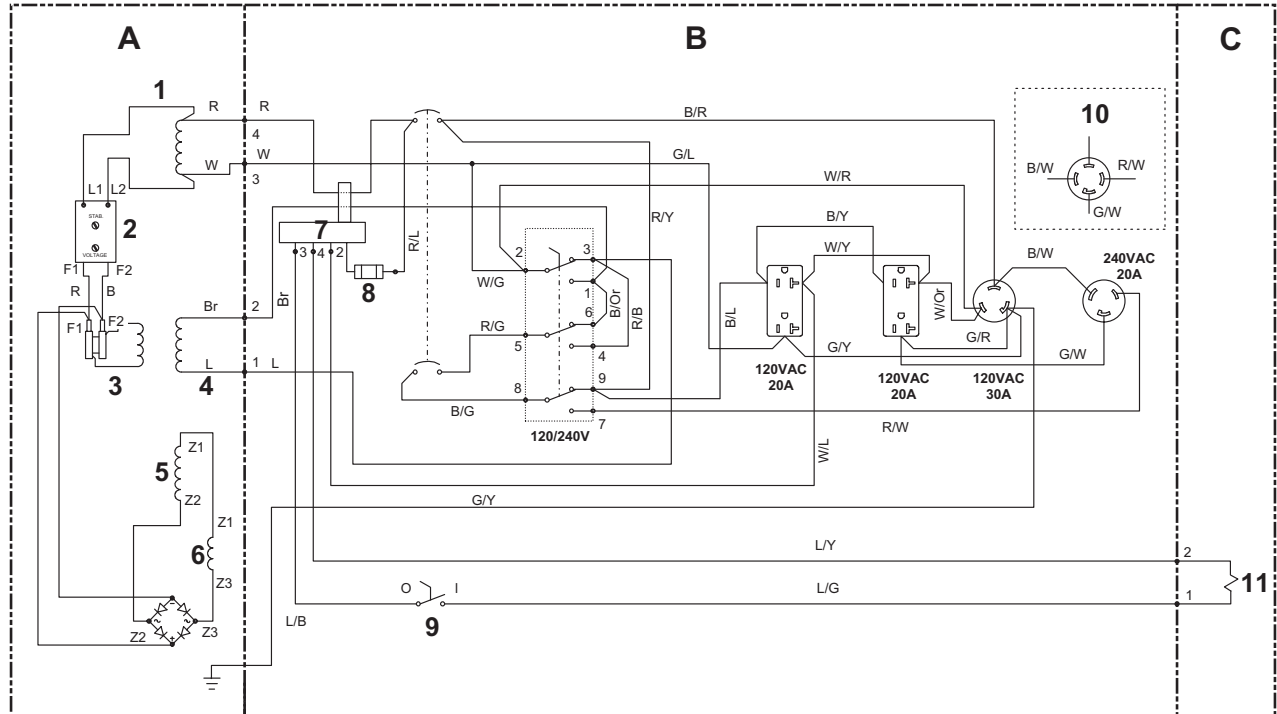

wc_gr000556

5.15 Engine Schematic

See Graphic: wc_gr000557

| Ref. | Description | Ref. | Description |
|------|------------------------|------|----------------------|
| A | Control Box | C | Engine |
| B | Electric Start Engines | D | Manual Start Engines |

| Ref. | Description | Ref. | Description |
|------|---------------------|------|-----------------|
| 1. | Engine Crank Switch | 5. | Solenoid |
| 1a. | OFF | 6. | Starter |
| 1b. | RUN | 7. | Charging Coil |
| 1c. | START | 8. | Battery |
| 2. | Oil Level Switch | 9. | Ignition Switch |
| 3. | Coil | 9a. | ON |
| 4. | 15 Amp Fuse | 9b. | OFF |

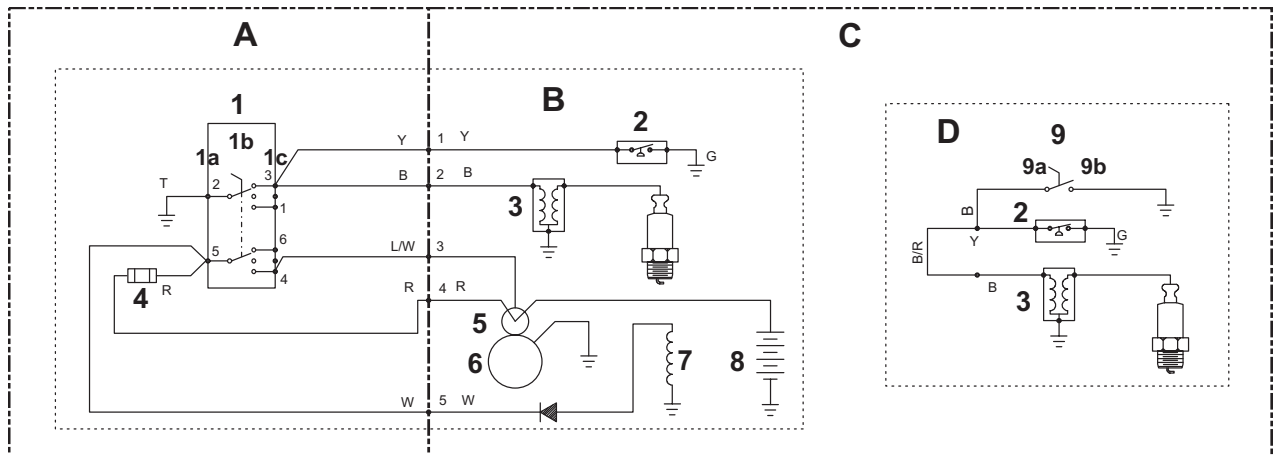

wc_gr000557

Notes:

