



An Oshkosh Corporation Company

Operation and Safety Manual

Original Instructions - Keep this manual with the machine at all times.

Boom Lift Models

400S

460SJ

ANSI **CE** 

The ANSI logo is in a bold, sans-serif font. The CE mark is also in a bold, sans-serif font. The SP logo consists of the letters 'SP' inside a globe-like grid.

3121216

May 25, 2012

FOREWORD

This manual is a very important tool! Keep it with the machine at all times.

The purpose of this manual is to provide owners, users, operators, lessors, and lessees with the precautions and operating procedures essential for the safe and proper machine operation for its intended purpose.

Due to continuous product improvements, JLG Industries, Inc. reserves the right to make specification changes without prior notification. Contact JLG Industries, Inc. for updated information.

SAFETY ALERT SYMBOLS AND SAFETY SIGNAL WORDS



This is the Safety Alert Symbol. It is used to alert you to the potential personal injury hazards. Obey all safety messages that follow this symbol to avoid possible injury or death

DANGER

INDICATES AN IMMINENTLY HAZARDOUS SITUATION. IF NOT AVOIDED, WILL RESULT IN SERIOUS INJURY OR DEATH. THIS DECAL WILL HAVE A RED BACKGROUND.

WARNING

INDICATES A POTENTIALLY HAZARDOUS SITUATION. IF NOT AVOIDED, COULD RESULT IN SERIOUS INJURY OR DEATH. THIS DECAL WILL HAVE AN ORANGE BACKGROUND.

CAUTION

INDICATES A POTENTIALLY HAZARDOUS SITUATION. IF NOT AVOIDED, MAY RESULT IN MINOR OR MODERATE INJURY. IT MAY ALSO ALERT AGAINST UNSAFE PRACTICES. THIS DECAL WILL HAVE A YELLOW BACKGROUND.

NOTICE

INDICATES INFORMATION OR A COMPANY POLICY THAT RELATES DIRECTLY OR INDIRECTLY TO THE SAFETY OF PERSONNEL OR PROTECTION OF PROPERTY.

⚠ WARNING

THIS PRODUCT MUST COMPLY WITH ALL SAFETY RELATED BULLETINS. CONTACT JLG INDUSTRIES, INC. OR THE LOCAL AUTHORIZED JLG REPRESENTATIVE FOR INFORMATION REGARDING SAFETY-RELATED BULLETINS WHICH MAY HAVE BEEN ISSUED FOR THIS PRODUCT.

NOTICE

JLG INDUSTRIES, INC. SENDS SAFETY RELATED BULLETINS TO THE OWNER OF RECORD OF THIS MACHINE. CONTACT JLG INDUSTRIES, INC. TO ENSURE THAT THE CURRENT OWNER RECORDS ARE UPDATED AND ACCURATE.

NOTICE

JLG INDUSTRIES, INC. MUST BE NOTIFIED IMMEDIATELY IN ALL INSTANCES WHERE JLG PRODUCTS HAVE BEEN INVOLVED IN AN ACCIDENT INVOLVING BODILY INJURY OR DEATH OF PERSONNEL OR WHEN SUBSTANTIAL DAMAGE HAS OCCURRED TO PERSONAL PROPERTY OR THE JLG PRODUCT.

For:

- Accident Reporting
- Product Safety Publications
- Current Owner Updates
- Questions Regarding Product Safety
- Standards and Regulations Compliance Information
- Questions Regarding Special Product Applications
- Questions Regarding Product Modifications

Contact:

Product Safety and Reliability Department
JLG Industries, Inc.
13224 Fountainhead Plaza
Hagerstown, MD 21742
USA

or Your Local JLG Office
(See addresses on inside of manual cover)

In USA:

Toll Free: 877-JLG-SAFE (877-554-7233)

Outside USA:

Phone: 240-420-2661
Fax: 301-745-3713
E-mail: ProductSafety@JLG.com

REVISION LOG

Original Issue	- June 8, 2005
Revised	- October 14, 2005
Revised	- February 8, 2006
Revised	- May 24, 2006
Revised	- July 31, 2007
Revised	- October 8, 2008
Revised	- November 5, 2009
Revised	- October 6, 2011
Revised	- May 25, 2012

SECTION - PARAGRAPH, SUBJECT	PAGE
SECTION - 1 - SAFETY PRECAUTIONS	
1.1 GENERAL	1-1
1.2 PRE-OPERATION	1-1
Operator Training and Knowledge	1-1
Workplace Inspection	1-2
Machine Inspection	1-2
1.3 OPERATION	1-3
General	1-3
Trip and Fall Hazards	1-3
Electrocution Hazards	1-4
Tipping Hazards	1-6
Crushing and Collision Hazards	1-7
1.4 TOWING, LIFTING, AND HAULING	1-8
1.5 ADDITIONAL HAZARDS / SAFETY	1-9
SECTION - 2 - USER RESPONSIBILITIES, MACHINE PREPARATION, AND INSPECTION	
2.1 PERSONNEL TRAINING	2-1
Operator Training	2-1
Training Supervision	2-1
Operator Responsibility	2-1
2.2 PREPARATION, INSPECTION, AND MAINTENANCE	2-2
Pre-Start Inspection	2-5
Functional Check	2-6

SECTION - PARAGRAPH, SUBJECT	PAGE
Walk-Around inspection	2-9
2.3 OSCILLATING AXLE LOCKOUT TEST (IF EQUIPPED)	2-11
SECTION - 3 - MACHINE CONTROLS AND INDICATORS	
3.1 GENERAL	3-1
3.2 CONTROLS AND INDICATORS	3-1
Ground Controls	3-2
Ground Control Indicator Panel	3-7
Platform Station	3-10
Platform Control Indicator Panel	3-16
SECTION - 4 - MACHINE OPERATION	
4.1 DESCRIPTION	4-1
4.2 OPERATING CHARACTERISTICS AND LIMITATIONS	4-1
Capacities	4-1
Stability	4-2
4.3 ENGINE OPERATION	4-4
Starting Procedure	4-4
Shutdown Procedure	4-5
4.4 TRAVELING (DRIVING)	4-5
Traveling Forward or Reverse	4-8

TABLE OF CONTENTS

SECTION - PARAGRAPH, SUBJECT	PAGE	SECTION - PARAGRAPH, SUBJECT	PAGE
4.5 STEERING	4-9	4.11 SHUT DOWN AND PARK	4-14
4.6 PARKING AND STOWING	4-9	4.12 TIE DOWN AND LIFTING	4-14
4.7 PLATFORM	4-9	4.13 TOWING	4-18
Loading from Ground Level	4-9	4.14 PLACARDS AND DECALS	4-19
Loading From Positions Above Ground Level	4-9		
Platform Level Adjustment	4-10	SECTION - 5 - EMERGENCY PROCEDURES	
Platform Rotation	4-10	5.1 GENERAL	5-1
4.8 BOOM	4-10	5.2 INCIDENT NOTIFICATION	5-1
Swinging the Boom	4-11	5.3 EMERGENCY OPERATION	5-1
Raising and Lowering the Main Boom	4-11	Operator Unable to Control Machine	5-1
Telescoping the Main Boom	4-11	Platform or Boom Caught Overhead	5-2
4.9 AUXILIARY POWER - NON ADE EQUIPPED		5.4 EMERGENCY TOWING PROCEDURES	5-2
MACHINES	4-12		
Activating from the Platform Control Station	4-12	SECTION - 6 - GENERAL SPECIFICATIONS & OPERATOR	
Activating from the Ground Control Station	4-12	MAINTENANCE	
4.10 AUXILIARY POWER - ADE EQUIPPED		6.1 INTRODUCTION	6-1
MACHINES	4-13	6.2 OPERATING SPECIFICATIONS	6-1
Activating from the Platform Control Station	4-13	Capacities	6-5
Activating from the Ground Control Station	4-13	Engine	6-6
		Tires	6-8
		Hydraulic Oil	6-9
		Critical Stability Weights	6-12
		Serial Number Location	6-13

SECTION - PARAGRAPH, SUBJECT	PAGE
6.3 OPERATOR MAINTENANCE	6-25
6.4 TIRES & WHEELS	6-31
Tire Inflation	6-31
Tire Damage	6-31
Tire Replacement	6-32
Wheel Replacement	6-32
Wheel Installation	6-33
6.5 DRAINING OIL BUILD UP FROM THE PROPANE REGULATOR (PRIOR TO S/N 0300109274)	6-34
6.6 PROPANE FUEL FILTER REPLACEMENT	6-36
Removal	6-36
Installation	6-36
6.7 PROPANE FUEL SYSTEM PRESSURE RELIEF	6-38
6.8 SUPPLEMENTAL INFORMATION	6-38

SECTION - 7 - INSPECTION AND REPAIR LOG

SECTION - PARAGRAPH, SUBJECT	PAGE
LIST OF FIGURES	
2-1. Basic Nomenclature	2-4
2-2. Daily Walk-Around Inspection - Sheet 1 of 3	2-8
2-3. Daily Walk-Around Inspection - Sheet 2 of 3	2-9
2-4. Daily Walk-Around Inspection - Sheet 3 of 3	2-10
3-1. Ground Control Station - S Models	3-3
3-2. Ground Control Station - SJ Models	3-4
3-3. Ground Control Indicator Panel (Prior to S/N 93233)	3-7
3-4. Ground Control Indicator Panel (S/N 93233 to Present)	3-8
3-5. Platform Control Console	3-11
3-6. Platform Control Console - w/Drive Orientation ..	3-12
3-7. Platform Control Indicator Panel	3-17
3-8. Platform Control Indicator Panel - w/Drive Orientation	3-17
4-1. Position Of Least Backward Stability	4-2
4-2. Position Of Least Forward Stability	4-3
4-3. Grades and Sideslopes	4-7
4-4. Machine Tie Down - 400S Models	4-15
4-5. Machine Tie Down - 460SJ Models	4-16
4-6. Lifting and Tie Down	4-17
4-7. Drive Disconnect Hub	4-18
4-8. Decal Installation - Sheet 1 of 4	4-20
4-9. Decal Installation - Sheet 2 of 4	4-21

TABLE OF CONTENTS

SECTION - PARAGRAPH, SUBJECT	PAGE
4-10. Decal Installation - Sheet 3 of 4	4-22
4-11. Decal Installation - Sheet 4 of 4	4-23
6-1. Serial Number Location	6-13
6-2. Engine Operating Temperature Specifications - Deutz - Sheet 1 of 2	6-14
6-3. Engine Operating Temperature Specifications - Deutz - Sheet 2 of 2	6-15
6-4. Engine Operating Temperature Specifications - Ford - Sheet 1 of 2	6-16
6-5. Engine Operating Temperature Specifications - Ford - Sheet 2 of 2	6-17
6-6. Engine Operating Temperature Specifications - Caterpillar - Sheet 1 of 2	6-18
6-7. Engine Operating Temperature Specifications - Caterpillar - Sheet 2 of 2	6-19
6-8. Engine Operating Temperature Specifications - GM - Sheet 1 of 2	6-20
6-9. Engine Operating Temperature Specifications - GM - Sheet 2 of 2	6-21
6-10. Engine Operating Temperature Specifications - Perkins - Sheet 1 of 2	6-22
6-11. Engine Operating Temperature Specifications - Perkins - Sheet 2 of 2	6-23
6-12. Operator Maintenance and Lubrication Diagram	6-24
6-13. Filter Lock Assembly	6-37

SECTION - PARAGRAPH, SUBJECT	PAGE
------------------------------	------

LIST OF TABLES

1-1	Minimum Approach Distances (M.A.D.)	1-5
1-2	Beaufort Scale (For Reference Only)	1-10
2-1	Inspection and Maintenance Table	2-3
4-1	Decals - 400S with 500 lb (227 or 230 kg) Capacity	4-24
4-2	Decals - 400S with 750 lb (340 kg) Capacity	4-28
4-3	Decals - 460SJ	4-32
6-1	Operating Specifications - 400S - Prior to S/N 0300142870	6-1
6-2	Operating Specifications - 400S - S/N 0300142870 to Present	6-2
6-3	Operating Specifications - 460SJ - Prior to S/N 0300142870	6-3
6-4	Operating Specifications - 460SJ - S/N 0300142870 to Present	6-4
6-5	Capacities	6-5
6-6	Ford LRG-425 (Gas or Dual Fuel)	6-6
6-7	Deutz F3M1011F/F3M2011F/D2011L03	6-6
6-8	Isuzu 4LE1	6-7
6-9	Caterpillar 3024/C2.2	6-7
6-10	GM 3.0L	6-7
6-11	Perkins 404D-22	6-8
6-12	Tires	6-8
6-13	Hydraulic Oil	6-9

TABLE OF CONTENTS

SECTION - PARAGRAPH, SUBJECT	PAGE	SECTION - PARAGRAPH, SUBJECT	PAGE
6-14 Mobilfluid 424 Specs	6-9		
6-15 UCon Hydrolube HP-5046	6-10		
6-16 Mobil EAL 224H Specs.	6-10		
6-17 Mobil EAL EnviroSyn H Specs	6-11		
6-18 Exxon Univas HVI 26 Specs	6-11		
6-19 Critical Stability Weights.	6-12		
6-20 Lubrication Specifications	6-25		
6-21 Wheel Torque Chart	6-34		
7-1 Inspection and Repair Log	7-1		

TABLE OF CONTENTS

SECTION - PARAGRAPH, SUBJECT

PAGE

SECTION - PARAGRAPH, SUBJECT

PAGE

This page left blank intentionally.

SECTION 1. SAFETY PRECAUTIONS

1.1 GENERAL

This section outlines the necessary precautions for proper and safe machine operation and maintenance. For proper machine use, it is mandatory that a daily routine is established based on the content of this manual. A maintenance program, using the information provided in this manual and the Service and Maintenance Manual, must also be established by a qualified person and followed to ensure the machine is safe to operate.

The owner/user/operator/lessor/lessee of the machine should not operate the machine until this manual has been read, training is accomplished, and operation of the machine has been completed under the supervision of an experienced and qualified operator.

If there are any questions with regard to safety, training, inspection, maintenance, application, and operation, please contact JLG Industries, Inc. ("JLG").

WARNING

FAILURE TO COMPLY WITH THE SAFETY PRECAUTIONS LISTED IN THIS MANUAL COULD RESULT IN MACHINE DAMAGE, PROPERTY DAMAGE, PERSONAL INJURY OR DEATH.

1.2 PRE-OPERATION

Operator Training and Knowledge

- Read and understand this manual before operating the machine.

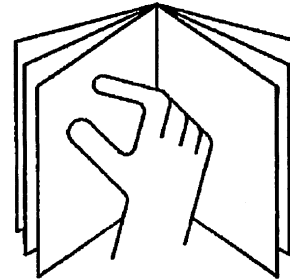

- Do not operate this machine until complete training is performed by authorized persons.
- Only authorized and qualified personnel can operate the machine.

SECTION 1 - SAFETY PRECAUTIONS

- Read, understand, and obey all DANGERS, WARNINGS, CAUTIONS, and operating instructions on the machine and in this manual.
- Use the machine in a manner which is within the scope of its intended application set by JLG.
- All operating personnel must be familiar with the emergency controls and emergency operation of the machine as specified in this manual.
- Read, understand, and obey all applicable employer, local, and governmental regulations as they pertain to operation of the machine.

Workplace Inspection

- The operator is to take safety measures to avoid all hazards in the work area prior to machine operation.
- Do not operate or raise the platform while on trucks, trailers, railway cars, floating vessels, scaffolds or other equipment unless approved in writing by JLG.
- Do not operate the machine in hazardous environments unless approved for that purpose by JLG.
- Be sure that the ground conditions are able to support the maximum load shown on the decals located on the machine.

Machine Inspection

- Before machine operation, perform inspections and functional checks. Refer to Section 2 of this manual for detailed instructions.
- Do not operate this machine until it has been serviced and maintained according to requirements specified in the Service and Maintenance Manual.
- Be sure the footswitch and all other safety devices are operating properly. Modification of these devices is a safety violation.

WARNING

MODIFICATION OR ALTERATION OF AN AERIAL WORK PLATFORM SHALL BE MADE ONLY WITH WRITTEN PERMISSION FROM THE MANUFACTURER

- Do not operate any machine on which safety or instruction placards or decals are missing or illegible.
- Avoid any buildup of debris on the platform floor. Keep mud, oil, grease, and other slippery substances from footwear and platform floor.

1.3 OPERATION

General

- Do not use the machine for any purpose other than positioning personnel, their tools, and equipment.
 - Never operate a machine that is not working properly. If a malfunction occurs, shut down the machine.
 - Never slam a control switch or lever through neutral to an opposite direction. Always return switch to neutral and stop before moving the switch to the next function. Operate controls with slow and even pressure.
 - Hydraulic cylinders should never be left fully extended or fully retracted before shutdown or for long periods of time.
 - Do not allow personnel to tamper with or operate the machine from the ground with personnel in the platform, except in an emergency.
 - Do not carry materials directly on platform railing. Contact JLG for approved material handling accessories.
 - When two or more persons are in the platform, the operator shall be responsible for all machine operations.
 - Always ensure that power tools are properly stowed and never left hanging by their cord from the platform work area.
- Supplies or tools which extend outside the platform are prohibited unless approved by JLG.
 - When driving, always position boom over rear axle in line with the direction of travel. Remember, if boom is over the front axle, steer and drive functions will be reversed.
 - Do not assist a stuck or disabled machine by pushing, pulling, or by using boom functions. Only pull the unit from the tie-down lugs on the chassis.
 - Do not place boom or platform against any structure to steady the platform or to support the structure.
 - Stow boom and shut off all power before leaving machine.

Trip and Fall Hazards

During operation, occupants in the platform must wear a full body harness with a lanyard attached to an authorized lanyard anchorage point. Attach only one (1) lanyard per lanyard anchorage point.

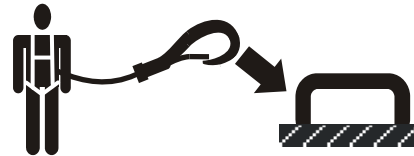

SECTION 1 - SAFETY PRECAUTIONS

- Before operating the machine, make sure all gates are closed and fastened in their proper position.

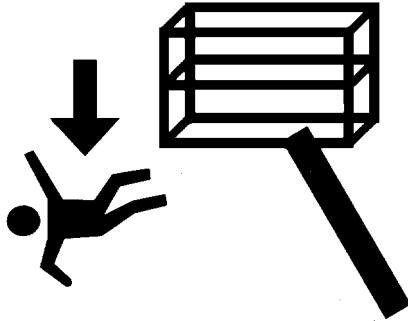

- Keep both feet firmly positioned on the platform floor at all times. Never use ladders, boxes, steps, planks, or similar items on platform to provide additional reach.
- Never use the boom assembly to enter or leave the platform.

- Use extreme caution when entering or leaving platform. Be sure that the boom is fully lowered. It may be necessary to telescope out to position the platform closer to the ground for entry/exit. Face the machine, maintain “three point contact” with the machine, using two hands and one foot or two feet and one hand during entry and exit.

Electrocution Hazards

- This machine is not insulated and does not provide protection from contact or proximity to electrical current.

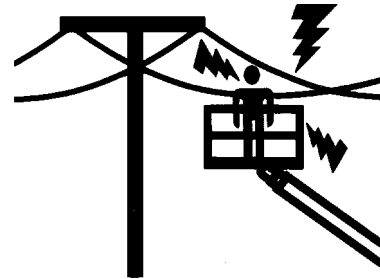

SECTION 1 - SAFETY PRECAUTIONS

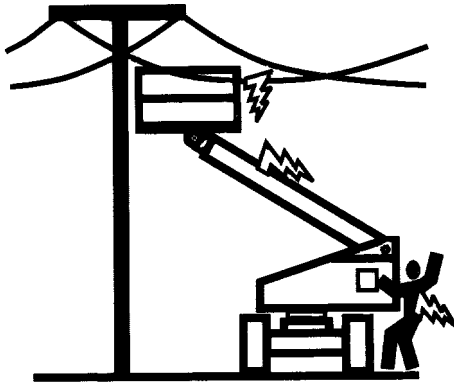

- Maintain distance from electrical lines, apparatus, or any energized (exposed or insulated) parts according to the Minimum Approach Distance (MAD) as shown in Table 1-1.
- Allow for machine movement and electrical line swaying.

Table 1-1. Minimum Approach Distances (M.A.D.)

Voltage Range (Phase to Phase)	MINIMUM APPROACH DISTANCE in Feet (Meters)
0 to 50 KV	10 (3)
Over 50KV to 200 KV	15 (5)
Over 200 KV to 350 KV	20 (6)
Over 350 KV to 500 KV	25 (8)
Over 500 KV to 750 KV	35 (11)
Over 750 KV to 1000 KV	45 (14)

NOTE: *This requirement shall apply except where employer, local or governmental regulations are more stringent.*

- Maintain a clearance of at least 10 ft. (3m) between any part of the machine and its occupants, their tools, and their equipment from any electrical line or apparatus carrying up to 50,000 volts. One foot additional clearance is required for every additional 30,000 volts or less.

SECTION 1 - SAFETY PRECAUTIONS

- The minimum approach distance may be reduced if insulating barriers are installed to prevent contact, and the barriers are rated for the voltage of the line being guarded. These barriers shall not be part of (or attached to) the machine. The minimum approach distance shall be reduced to a distance within the designed working dimensions of the insulating barrier. This determination shall be made by a qualified person in accordance with the employer, local, or governmental requirements for work practices near energized equipment

⚠ DANGER

DO NOT MANEUVER MACHINE OR PERSONNEL INSIDE PROHIBITED ZONE (MAD). ASSUME ALL ELECTRICAL PARTS AND WIRING ARE ENERGIZED UNLESS KNOWN OTHERWISE.

Tipping Hazards

- The user should be familiar with the surface before driving. Do not exceed the allowable sideslope and grade while driving.

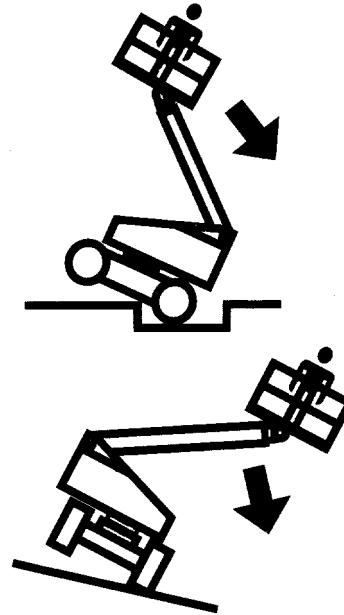

- Do not elevate platform or drive with platform elevated while on a sloping, uneven, or soft surface.
- Before driving on floors, bridges, trucks, and other surfaces, check allowable capacity of the surfaces.
- Never exceed the maximum platform capacity. Distribute loads evenly on platform floor.
- Do not raise the platform or drive from an elevated position unless the machine is on firm, level and smooth surfaces.
- Keep the chassis of the machine at least 2 ft. (0.6m) from holes, bumps, drop-offs, obstructions, debris, concealed holes, and other potential hazards on the floor/surface.
- Do not push or pull any object with the boom.
- Never attempt to use the machine as a crane. Do not tie-off machine to any adjacent structure.
- Do not operate the machine when wind conditions exceed 28 mph (12.5 m/s). Refer to Table 1-2, Beaufort Scale (For Reference Only).
- Do not increase the surface area of the platform or the load. Increase of the area exposed to the wind will decrease stability.
- Do not increase the platform size with unauthorized deck extensions or attachments.

- If boom assembly or platform is in a position that one or more wheels are off the ground, all persons must be removed before attempting to stabilize the machine. Use cranes, forklift trucks, or other appropriate equipment to stabilize machine.

Crushing and Collision Hazards

- Approved head gear must be worn by all operating and ground personnel.
- Check work area for clearances overhead, on sides, and bottom of platform when lifting or lowering platform, and driving.

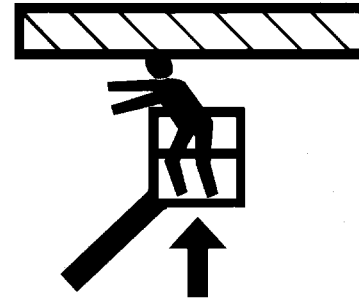

- During operation, keep all body parts inside platform railing.

SECTION 1 - SAFETY PRECAUTIONS

- Use the boom functions, not the drive function, to position the platform close to obstacles.
- Always post a lookout when driving in areas where vision is obstructed.
- Keep non-operating personnel at least 6 ft. (1.8m) away from machine during all driving and swing operations.
- Limit travel speed according to conditions of ground surface, congestion, visibility, slope, location of personnel, and other factors which may cause collision or injury to personnel.
- Be aware of stopping distances in all drive speeds. When driving in high speed, switch to low speed before stopping. Travel grades in low speed only.
- Do not use high speed drive in restricted or close quarters or when driving in reverse.
- Exercise extreme caution at all times to prevent obstacles from striking or interfering with operating controls and persons in the platform.
- Be sure that operators of other overhead and floor level machines are aware of the aerial work platform's presence. Disconnect power to overhead cranes.
- Warn personnel not to work, stand, or walk under a raised boom or platform. Position barricades on floor if necessary.

1.4 TOWING, LIFTING, AND HAULING

- Never allow personnel in platform while towing, lifting, or hauling.
- This machine should not be towed, except in the event of emergency, malfunction, power failure, or loading/unloading. Refer to the Emergency Procedures section of this manual for emergency towing procedures.
- Ensure boom is in the stowed position and the turntable locked prior to towing, lifting or hauling. The platform must be completely empty of tools.
- When lifting machine, lift only at designated areas of the machine. Lift the unit with equipment of adequate capacity.
- Refer to the Machine Operation section of this manual for lifting information.

1.5 ADDITIONAL HAZARDS / SAFETY

- Do not use machine as a ground for welding.
- When performing welding or metal cutting operations, precautions must be taken to protect the chassis from direct exposure to weld and metal cutting spatter.
- Do not refuel the machine with the engine running.
- Battery fluid is highly corrosive. Avoid contact with skin and clothing at all times.
- Charge batteries only in a well ventilated area.

SECTION 1 - SAFETY PRECAUTIONS

NOTICE

DO NOT OPERATE THE MACHINE WHEN WIND CONDITIONS EXCEED 28 MPH (12.5 M/S).

Table 1-2. Beaufort Scale (For Reference Only)

Beaufort Number	Wind Speed		Description	Land Conditions
	mph	m/s		
0	0	0-0.2	Calm	Calm. Smoke rises vertically.
1	1-3	0.3-1.5	Light air	Wind motion visible in smoke.
2	4-7	1.6-3.3	Light breeze	Wind felt on exposed skin. Leaves rustle.
3	8-12	3.4-5.4	Gentle breeze	Leaves and smaller twigs in constant motion.
4	13-18	5.5-7.9	Moderate breeze	Dust and loose paper raised. Small branches begin to move.
5	19-24	8.0-10.7	Fresh breeze	Smaller trees sway.
6	25-31	10.8-13.8	Strong breeze	Large branches in motion. Whistling heard in overhead wires. Umbrella use becomes difficult.
7	32-38	13.9-17.1	Near Gale/Moderate Gale	Whole trees in motion. Effort needed to walk against the wind.
8	39-46	17.2-20.7	Fresh Gale	Twigs broken from trees. Cars veer on road.
9	47-54	20.8-24.4	Strong Gale	Light structure damage.

SECTION 2. USER RESPONSIBILITIES, MACHINE PREPARATION, AND INSPECTION

2.1 PERSONNEL TRAINING

The aerial platform is a personnel handling device; so it is necessary that it be operated and maintained only by trained personnel.

Persons under the influence of drugs or alcohol or who are subject to seizures, dizziness or loss of physical control must not operate this machine.

Operator Training

Operator training must cover:

1. Use and limitations of the controls in the platform and at the ground, emergency controls and safety systems.
2. Control labels, instructions, and warnings on the machine.
3. Rules of the employer and government regulations.
4. Use of approved fall protection device.
5. Enough knowledge of the mechanical operation of the machine to recognize a malfunction or potential malfunction.

6. The safest means to operate the machine where overhead obstructions, other moving equipment, and obstacles, depressions, holes, drop-offs.
7. Means to avoid the hazards of unprotected electrical conductors.
8. Specific job requirements or machine application.

Training Supervision

Training must be done under the supervision of a qualified person in an open area free of obstructions until the trainee has developed the ability to safely control and operate the machine.

Operator Responsibility

The operator must be instructed that he/she has the responsibility and authority to shut down the machine in case of a malfunction or other unsafe condition of either the machine or the job site.

2.2 PREPARATION, INSPECTION, AND MAINTENANCE

The following table covers the periodic machine inspections and maintenance required by JLG Industries, Inc. Consult local regulations for further requirements for aerial work platforms. The frequency of inspections and maintenance must be increased as necessary when the machine is used in a harsh or hostile environment, if the machine is used with increased frequency, or if the machine is used in a severe manner.

NOTICE

JLG INDUSTRIES, INC. RECOGNIZES A FACTORY-TRAINED SERVICE TECHNICIAN AS A PERSON WHO HAS SUCCESSFULLY COMPLETED THE JLG SERVICE TRAINING SCHOOL FOR THE SPECIFIC JLG PRODUCT MODEL.

SECTION 2 - USER RESPONSIBILITIES, MACHINE PREPARATION, AND INSPECTION

Table 2-1. Inspection and Maintenance Table

Type	Frequency	Primary Responsibility	Service Qualification	Reference
Pre-Start Inspection	Before using each day; or whenever there's an Operator change.	User or Operator	User or Operator	Operator and Safety Manual
Pre-Delivery Inspection (See Note)	Before each sale, lease, or rental delivery.	Owner, Dealer, or User	Qualified JLG Mechanic	Service and Maintenance Manual and applicable JLG inspection form
Frequent Inspection (See Note)	In service for 3 months or 150 hours, whichever comes first; or Out of service for a period of more than 3 months; or Purchased used.	Owner, Dealer, or User	Qualified JLG Mechanic	Service and Maintenance Manual and applicable JLG inspection form
Annual Machine Inspection (See Note)	Annually, no later than 13 months from the date of prior inspection.	Owner, Dealer, or User	Factory-Trained Service Technician (Recommended)	Service and Maintenance Manual and applicable JLG inspection form
Preventative Maintenance	At intervals as specified in the Service and Maintenance Manual.	Owner, Dealer, or User	Qualified JLG Mechanic	Service and Maintenance Manual
NOTE: Inspection forms are available from JLG. Use the Service and Maintenance Manual to perform inspections.				

SECTION 2 - USER RESPONSIBILITIES, MACHINE PREPARATION, AND INSPECTION

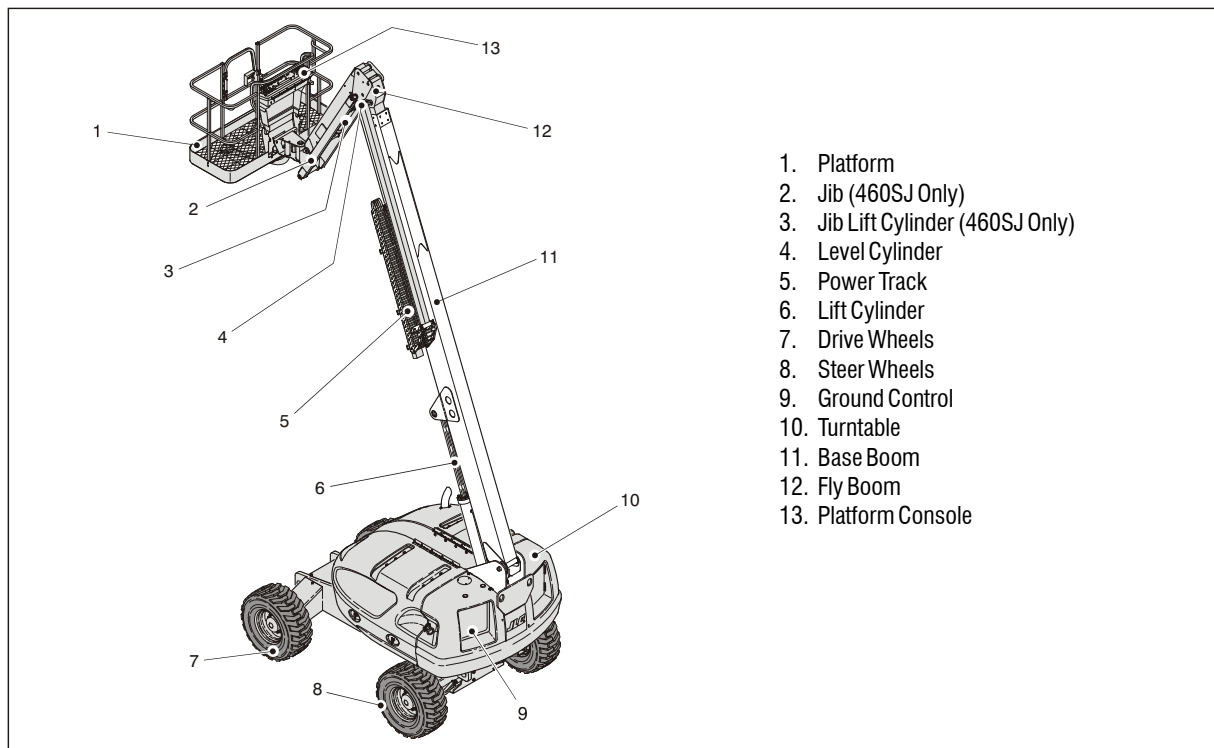

Figure 2-1. Basic Nomenclature

Pre-Start Inspection

The Pre-Start Inspection should include each of the following:

1. **Cleanliness** – Check all surfaces for leakage (oil, fuel, or battery fluid) or foreign objects. Report any leakage to the proper maintenance personnel.
2. **Decals and Placards** – Check all for cleanliness and legibility. Make sure none of the decals and placards are missing. Make sure all illegible decals and placards are cleaned or replaced.
3. **Operation and Safety Manuals** – Make sure a copy of the Operator and Safety Manual, AEM Safety Manual (ANSI markets only), and ANSI Manual of Responsibilities (ANSI markets only) is enclosed in the weather resistant storage container.
4. **“Walk-Around” Inspection** – Refer to Figure 2-2. thru Figure 2-4.
5. **Battery** – Charge as required.
6. **Fuel** (Combustion Engine Powered Machines) – Add the proper fuel as necessary.
7. **Engine Oil Supply** - Ensure the engine oil level is at the Full mark on the dipstick and the filler cap is secure.
8. **Hydraulic Oil** – Check the hydraulic oil level. Ensure hydraulic oil is added as required.
9. **Accessories/Attachments** - Reference the Operator and Safety Manual of each attachment or accessory installed upon the machine for specific inspection, operation, and maintenance instructions.
10. **Function Check** – Once the “Walk-Around” Inspection is complete, perform a functional check of all systems in an area free of overhead and ground level obstructions. Refer to Section 4 for more specific operating instructions.

WARNING

IF THE MACHINE DOES NOT OPERATE PROPERLY, TURN OFF THE MACHINE IMMEDIATELY! REPORT THE PROBLEM TO THE PROPER MAINTENANCE PERSONNEL. DO NOT OPERATE THE MACHINE UNTIL IT IS DECLARED SAFE FOR OPERATION.

SECTION 2 - USER RESPONSIBILITIES, MACHINE PREPARATION, AND INSPECTION

Functional Check

First, using the ground controls, check all functions controlled by the ground controls. Next, using the platform controls, check all functions controlled by the platform controls.

1. Telescope boom IN and OUT several cycles at various degrees of elevation lengths. Check for smooth telescope operation.
2. Swing turntable to LEFT and RIGHT a minimum of 45 degrees. Check for smooth motion.

NOTE: *Step 3 is only applicable for machines prior to S/N 0300140365.*

3. Check the oscillating axle valve (if equipped) under the turntable at the top front of frame. Observe that the valve plunger is depressed when turntable is positioned forward, and centered. Swing the turntable until bracket is past the valve. The plunger should be fully extended.

NOTE: *Step 4 is only applicable for machines prior to S/N 61718.*

4. With the aid of an assistant to monitor the CHASSIS OUT OF LEVEL indicator light on the platform control

console, manually activate the indicator light by compressing any one of the three tilt indicator mounting springs. If the light does not illuminate, shut down machine and contact a qualified service technician before continuing operation.

NOTE: *Step 5 is applicable for machines built from S/N 61718 to present.*

5. Check the chassis out of level indicator located on the platform control console by driving, with the machine in level position, up a suitable ramp of at least 5° slope. Check the out of level indicator, with the machine on the ramp. If the light does not illuminate, return the machine to a level surface, shut down the machine, and contact a qualified technician before resuming operation.
6. Check that platform self-leveling system functions properly during raising and lowering of boom.
7. Check rotator for smooth operation and assure platform will rotate 90 degrees in both directions from centerline of boom.
8. Drive forward and reverse; check for proper operation.
9. Check boom horizontal limit switches to see that they are operable and not damaged. Raise and lower Boom. Check for smooth operation.

SECTION 2 - USER RESPONSIBILITIES, MACHINE PREPARATION, AND INSPECTION

NOTE: When the boom is raised above horizontal, high drive speed is cut out.

10. Steer left and right; check for proper operation.
11. Footswitch.

NOTICE

FOOTSWITCH MUST BE ADJUSTED SO THAT FUNCTIONS WILL OPERATE WHEN PEDAL IS APPROXIMATELY AT ITS CENTER OF TRAVEL. IF SWITCH OPERATES WITHIN LAST 1/4" OF TRAVEL, TOP OR BOTTOM, IT SHOULD BE ADJUSTED.

- a. Activate hydraulic system, by depressing footswitch. Operate Telescope and hold control. Remove foot from footswitch, motion should stop. If it does not, shut down machine and contact a trained JLG service technician.
- b. With footswitch depressed, operate Lift and hold control. Remove foot from footswitch, motion should stop. If it does not, shut down machine and contact a trained JLG service technician.
- c. With engine power shut down, depress the footswitch. Attempt to start engine. Engine should not attempt to start when footswitch is depressed. If starter engages or engine turns over, shut down

machine and contact a trained JLG service technician.

12. Auxiliary Power.

Operate each function control switch (e.g. Tele, Lift, and Swing) to ensure they function in both directions using auxiliary power.

13. Ground Controls.

Place Ground/Platform Select switch to Ground. Start engine. Platform controls should not operate.

SECTION 2 - USER RESPONSIBILITIES, MACHINE PREPARATION, AND INSPECTION

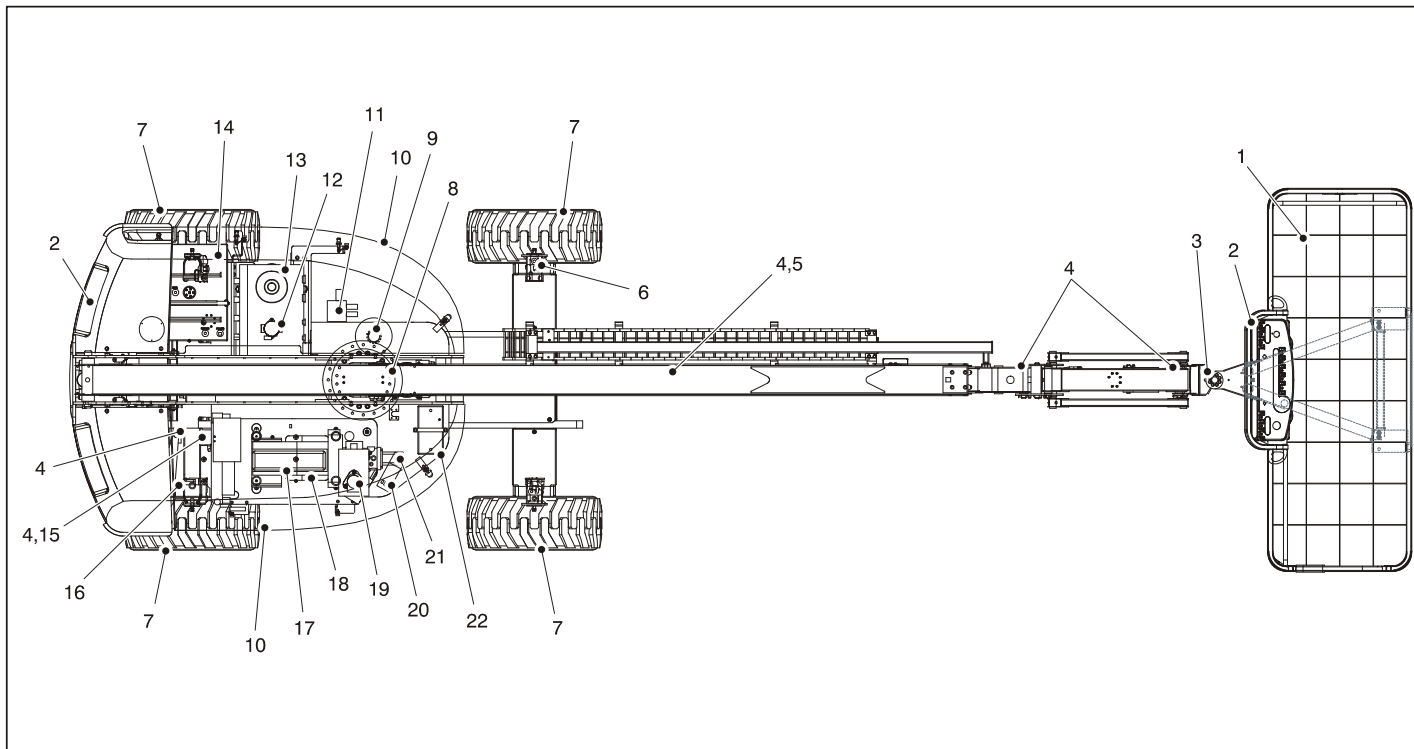

Figure 2-2. Daily Walk-Around Inspection - Sheet 1 of 3

Walk-Around inspection

Begin the "Walk-Around Inspection" at Item 1, as noted on the diagram. Continue to the right (counterclockwise viewed from top) checking each item in sequence for the conditions listed in the Walk-Around Inspection Checklist.

WARNING

TO AVOID INJURY, BE SURE MACHINE POWER IS OFF.

DO NOT OPERATE MACHINE UNTIL ALL MALFUNCTIONS HAVE BEEN CORRECTED.

INSPECTION NOTE: *On all components, make sure there are no loose or missing parts, that they are securely fastened, and no visible damage, leaks or excessive wear exists in addition to any other criteria mentioned.*

1. Platform Assembly and Gate - Footswitch in good working order, not modified, disabled or blocked.
2. Platform & Ground Control Consoles - Switches and levers return to neutral, decals/placards secure and legible, control markings legible.
3. Rotator - See Inspection Note.
4. All Hydraulic Cylinders - No visible damage; pivot pins and hydraulic hoses undamaged, not leaking.
5. Boom - See Inspection Note.
6. Drive Motor, Brake, and Hub - See Inspection Note.
7. Wheel/Tire Assembly - No loose or missing lug nuts, proper inflation (pneumatic). Inspect for worn tread, cuts, tears or other discrepancies. Inspect wheels for damage and corrosion.
8. Turntable Bearing - Evidence of proper lubrication; no evidence of loose bolts or looseness between bearing or structure.
9. Swing Drive - See Inspection Note.
10. Hood - See Inspection Note.
11. Control Valve - See Inspection Note.
12. Hydraulic Filter - See Inspection Note.
13. Hydraulic Oil Supply - Recommended oil level sight gauge. (Check level with cold oil, systems shut down, machine in stowed position) Cap in place and secure.

Figure 2-3. Daily Walk-Around Inspection - Sheet 2 of 3

SECTION 2 - USER RESPONSIBILITIES, MACHINE PREPARATION, AND INSPECTION

14. Fuel Supply - Filler cap secure, no visible damage to the tank or evidence of leaks.

NOTE: Lockout Valves were used prior to S/N 0300140365.

15. Oscillating Axle, Lockout Valves - See Inspection Note.

16. Tie Rod Ends and Steering Spindles - See Inspection Note.

17. Engine Air Filter - Element clean. See Inspection Note.

18. Engine Oil Supply - Full mark on dipstick; filler cap secure.

19. Muffler and Exhaust System - See Inspection Note.

20. Auxiliary Power Pump - See Inspection Note.

21. Hydraulic Pump - See Inspection Note.

22. Battery - Proper electrolyte levels; cables tight, no visible damage or corrosion.

Figure 2-4. Daily Walk-Around Inspection - Sheet 3 of 3

2.3 OSCILLATING AXLE LOCKOUT TEST (IF EQUIPPED)

NOTICE

LOCKOUT SYSTEM TEST MUST BE PERFORMED QUARTERLY, ANY TIME A SYSTEM COMPONENT IS REPLACED, OR WHEN IMPROPER SYSTEM OPERATION IS SUSPECTED.

NOTE: *Ensure boom is fully retracted, lowered, and centered between drive wheels prior to beginning lock-out cylinder test.*

1. Place a 6 inches (15.2 cm) high block with ascension ramp in front of left front wheel.
2. From platform control station, start engine
3. Place DRIVE control lever to FORWARD position and carefully drive machine up ascension ramp until left front wheel is on top of block.
4. Carefully activate SWING control lever and position boom over right side of machine.
5. With boom over right side of machine, place DRIVE control lever to REVERSE and drive machine off of block and ramp.
6. Have an assistant check to see that left front or right rear wheel remains elevated in position off of ground.
7. Carefully activate SWING control lever and return boom to stowed position (centered between drive wheels). When boom reaches center, stowed position, lockout cylinders should release and allow wheel to rest on ground, it may be necessary activate DRIVE to release cylinders.
8. Place the 6 inches (15.2 cm) high block with ascension ramp in front of right front wheel.
9. Place DRIVE control lever to FORWARD and carefully drive machine up ascension ramp until right front wheel is on top of block.

SECTION 2 - USER RESPONSIBILITIES, MACHINE PREPARATION, AND INSPECTION

10. With boom over left side, place DRIVE control lever to REVERSE and drive machine off block and ramp.
11. Have an assistant check to see that right front or left rear wheel remains elevated in position off of ground.
12. Carefully activate SWING control lever and return boom to stowed position (centered between drive wheels). When boom reaches center, stowed position, lockout cylinders should release and allow wheel to rest on ground, it may be necessary activate DRIVE to release cylinders.
13. If lockout cylinders do not function properly, have qualified personnel correct the malfunction prior to any further operation.

SECTION 3. MACHINE CONTROLS AND INDICATORS

3.1 GENERAL

NOTICE

THE MANUFACTURER HAS NO DIRECT CONTROL OVER MACHINE APPLICATION AND OPERATION. THE USER AND OPERATOR ARE RESPONSIBLE FOR CONFORMING WITH GOOD SAFETY PRACTICES.

This section provides the necessary information needed to understand control functions.

3.2 CONTROLS AND INDICATORS

NOTE: All machines are equipped with control panels that use symbols to indicate control functions. On ANSI machines refer to decal located on the control box guard in front of the control box or by the ground controls for these symbols and the corresponding functions.

NOTE: The indicator panels use different shaped symbols to alert the operator to different types of operational situations that could arise. The meaning of those symbols are explained below.



Indicates a potentially hazardous situation, which if not corrected, could result in serious injury or death. This indicator will be red.



Indicates an abnormal operating condition, which if not corrected, may result in machine interruption or damage. This indicator will be yellow.



Indicates important information regarding the operating condition, i.e. procedures essential for safe operation. This indicator will be green with the exception of the capacity indicator which will be green or yellow depending upon platform position.

SECTION 3 - MACHINE CONTROLS AND INDICATORS

Ground Controls

See Figure 3-1., Ground Control Station - S Models and Figure 3-2., Ground Control Station - SJ Models

PERFORM PRE-OPERATIONAL CHECKS AND INSPECTIONS FROM THE GROUND CONTROL STATION. WHEN PERSONNEL ARE IN THE PLATFORM, OPERATION OF THE BOOM WILL ONLY BE PERFORMED WITH THE PERMISSION OF THE PLATFORM OCCUPANT(S).

NOTE: Engine Start/Auxiliary Power, Main Lift, Swing, Platform Level, Main Telescope, and Platform Rotator control switches are spring-loaded and will automatically return to neutral (off) when released.

⚠ CAUTION

TO AVOID SERIOUS INJURY, DO NOT OPERATE MACHINE IF ANY CONTROL LEVERS OR TOGGLE SWITCHES CONTROLLING PLATFORM MOVEMENT DO NOT RETURN TO THE OFF POSITION WHEN RELEASED.

NOTE: If equipped, the Function Enable switch must be held down in order to operate Telescope, Swing, Lift, Jib Lift, Platform Level Override, and Platform Rotate functions.



1. Platform Rotate.

Permits rotation of the platform when positioned to the left or right.

⚠ WARNING

ONLY USE THE PLATFORM LEVELING OVERRIDE FUNCTION FOR SLIGHT LEVELING OF THE PLATFORM. INCORRECT USE COULD CAUSE THE LOAD/OCCUPANTS TO SHIFT OR FALL. FAILURE TO DO SO COULD RESULT IN DEATH OR SERIOUS INJURY.

2. Platform Leveling Override

A three position switch allows the operator to adjust the automatic self leveling system. This switch is used to adjust the platform level in situations such as ascending/descending a grade.

3. Articulating Jib Boom. (If Equipped)

Provides raising and lowering of the jib when positioned up or down.

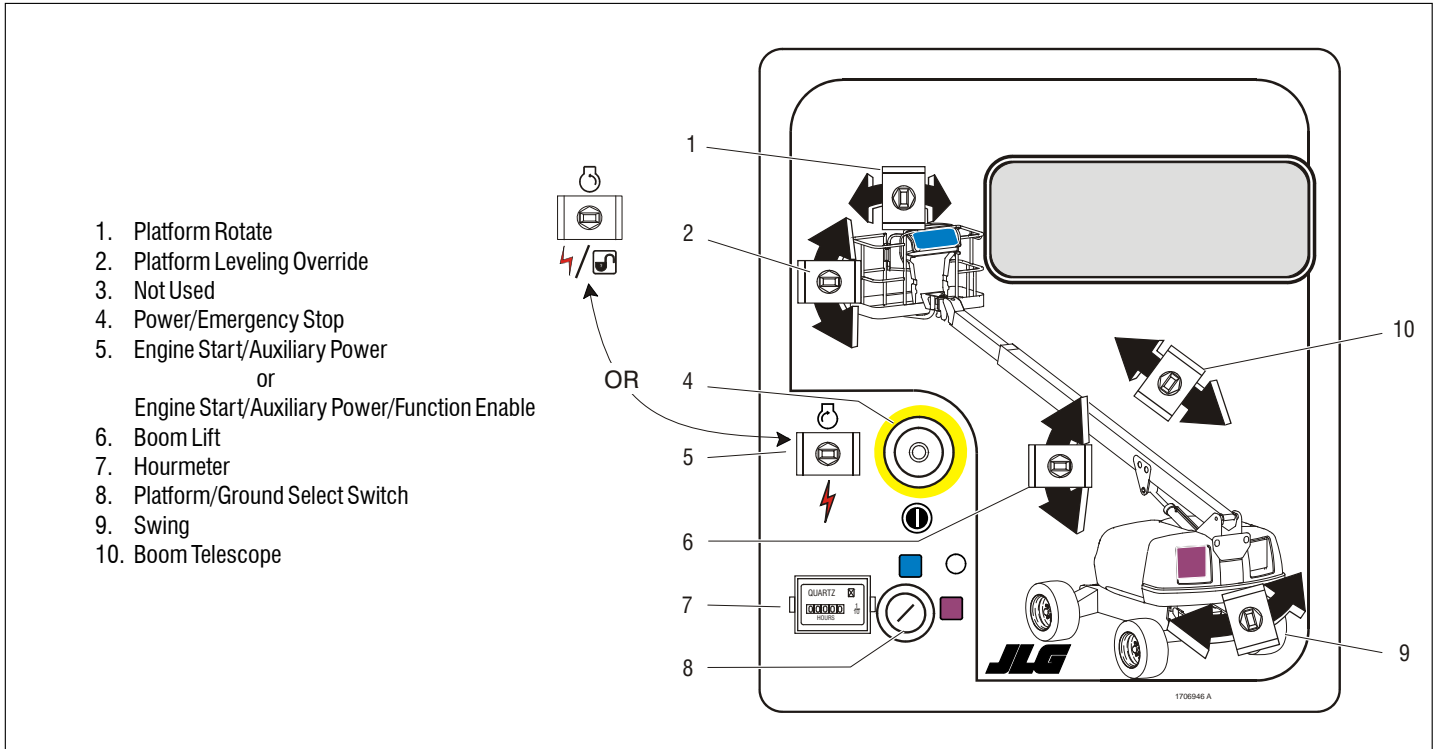

Figure 3-1. Ground Control Station - S Models

SECTION 3 - MACHINE CONTROLS AND INDICATORS

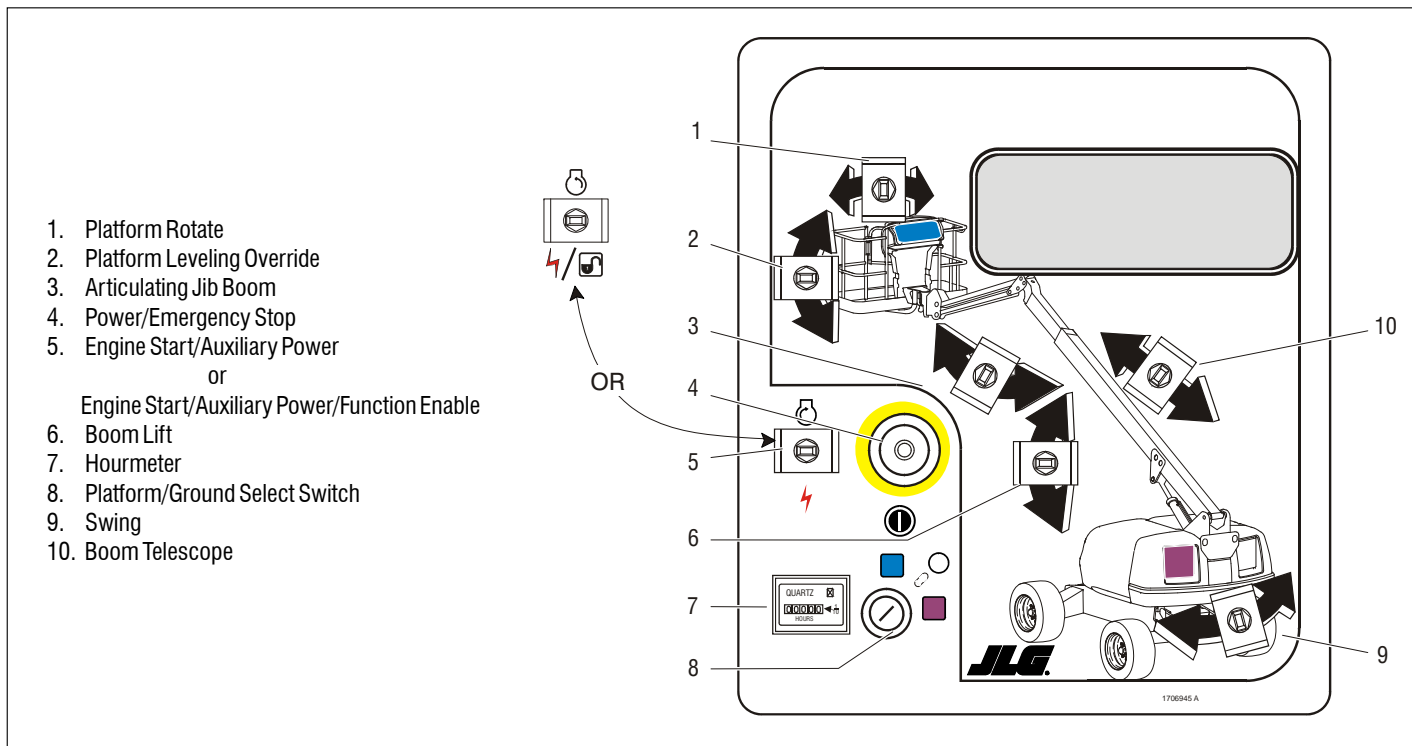

Figure 3-2. Ground Control Station - SJ Models

CAUTION

WHEN THE MACHINE IS SHUT DOWN THE MASTER/EMERGENCY STOP SWITCH MUST BE POSITIONED TO THE OFF POSITION TO PREVENT DRAINING THE BATTERY.

4. Power/Emergency Stop Switch.

A two-position red mushroom shaped switch supplies power to PLATFORM/GROUND SELECT switch when pulled out (on). When pushed in (off), power is shut off to the PLATFORM/GROUND SELECT switch.

NOTE: *When Power/Emergency Stop switch is in the on position and engine is not running, an alarm will sound, indicating Ignition is on.*

5. Engine Start/Auxiliary Power Switch or

Engine Start/ Auxiliary Power Switch /Function Enable.



To start the engine, the switch must be held "UP" until the engine starts.



To use auxiliary power, the switch must be held "DOWN" for duration of auxiliary pump use. Aux power can only be used if the engine is not running.



If equipped, the enable switch must be held "DOWN" to enable all boom controls when the engine is running.

NOTE: *Auxiliary power only works if there is no oil pressure, and is disabled if engine is running.*

SECTION 3 - MACHINE CONTROLS AND INDICATORS

CAUTION

WHEN OPERATING THE BOOM ENSURE THERE ARE NO PERSONNEL AROUND OR UNDER PLATFORM.

6. Boom Lift Control.

Provides raising and lowering of the boom when positioned up or down.

7. Hourmeter.

Registers the amount of time the machine has been in use, with the engine running. By connecting into the oil pressure circuit of the engine, only engine run hours are recorded. The hourmeter registers up to 9,999.9 hours and cannot be reset.

8. Platform/Ground Select Switch.

Supplies power to the platform control console when positioned to PLATFORM. With the switch in GROUND position, power is shut off to the platform control console, and only the controls on the ground control panel are operable.

NOTE: *With the Platform/Ground Select Switch in the center position, power is shut off to controls at both operating stations. Remove the key to prevent the controls from being actuated.*

9. Swing Control.

Provides 360 degrees non-continuous turntable rotation when positioned to the right or left.

10. Main Telescope Control.

Provides extension and retraction of the main boom, when positioned to in or out.

Ground Control Indicator Panel

See Figure 3-3., Ground Control Indicator Panel (Prior to S/N 93233) and Figure 3-4., Ground Control Indicator Panel (S/N 93233 to Present)

1. Battery Charging Indicator.

Indicates a problem in the battery or charging circuit and service is required.

2. Engine Oil Pressure Indicator.

Indicates that engine oil pressure is below normal and service is required.

3. Engine Coolant Temperature (Ford and Isuzu) Indicator.

Indicates that engine coolant temperature is abnormally high and service is required.

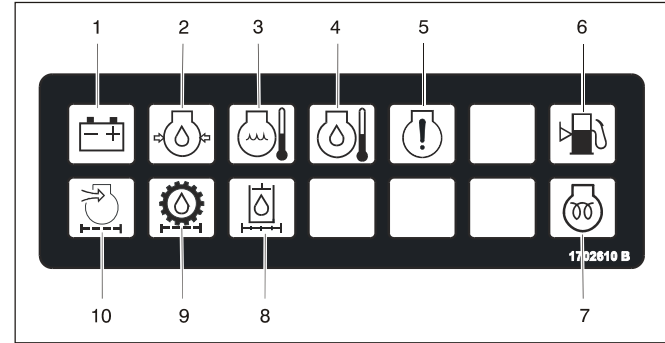

- | | |
|------------------------|------------------------------|
| 1. Battery Charging | 6. Low Fuel |
| 2. Engine Oil Pressure | 7. Glow Plug |
| 3. Engine Coolant Temp | 8. Hyd. Filter Bypass |
| 4. Engine Oil Temp | 9. Trans Filter Bypass |
| 5. Engine Malfunction | 10. Engine Air Filter Bypass |

Figure 3-3. Ground Control Indicator Panel (Prior to S/N 93233)

SECTION 3 - MACHINE CONTROLS AND INDICATORS

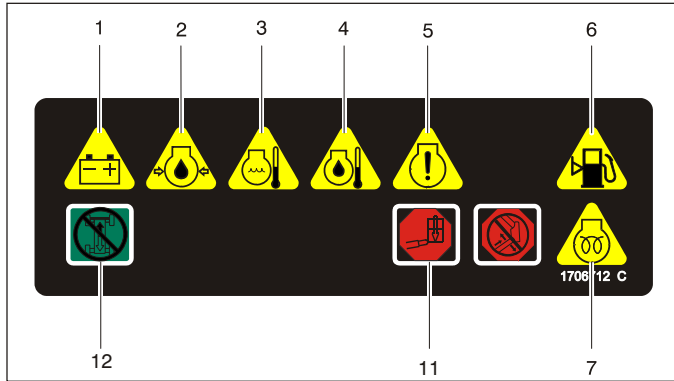

- | | |
|------------------------|-------------------------------|
| 1. Battery Charging | 7. Glow Plug |
| 2. Engine Oil Pressure | 8. Not Used |
| 3. Engine Coolant Temp | 9. Not Used |
| 4. Engine Oil Temp | 10. Not Used |
| 5. Engine Malfunction | 11. Platform Overload CE Only |
| 6. Low Fuel | 12. Drive and Steer Disable |

Figure 3-4. Ground Control Indicator Panel (S/N 93233 to Present)

4. Engine Oil Temperature Indicator (Deutz).

Indicates that the temperature of the engine oil, which also serves as engine coolant, is abnormally high and service is required.

5. Engine Malfunction Indicator. (Ford Only, prior to S/N 61718)

If an electrical malfunction occurs, this light will illuminate and stay lit until problem is eliminated. To find the specific malfunction, use the test of the EFI diagnostics Engine Control Module To show flash code of problem area.

6. Low Fuel Level Indicator.

Indicates that the fuel level is 1/8 full or less. When the light first turns on, there are approximately four usable gallons of fuel remaining.

SECTION 3 - MACHINE CONTROLS AND INDICATORS

7. Glow Plug Wait Indicator. (Diesel)

Indicates the glow plugs are on. The glow plugs are automatically turned on with the ignition circuit and remain on for approximately seven seconds. Start the engine only after the light goes out.

8. Hydraulic Filter Bypass Indicator.

Indicates that the return oil filter is too restrictive and needs to be replaced.

9. Transmission Pump Oil Filter Indicator.

Indicates that charge pump filter is too restrictive and needs to be replaced. This indicator has an integral temperature sensor (70 degrees F.) so that false signals are not generated when the hydraulic oil is below normal operating temperature.

10. Engine Air Filter Indicator.

Indicates the air filter is too restrictive and needs to be replaced.

11. Platform Overload (CE Only)

Indicates the platform has been overloaded.

12. Drive and Steer Disable Indicator (If equipped)

Indicates the Drive and Steer Disable function has been activated.

Platform Station

See Figure 3-5., Platform Control Console and Figure 3-6., Platform Control Console - w/Drive Orientation

When starting at platform, the Platform/Ground Switch, at the ground control box be selected platform, and the large red Power Stop Button be pulled out at platform and ground control.

WARNING

TO AVOID SERIOUS INJURY, DO NOT OPERATE MACHINE IF ANY CONTROL LEVERS OR TOGGLE SWITCHES CONTROLLING PLATFORM MOVEMENT DO NOT RETURN TO THE OFF OR NEUTRAL POSITION WHEN RELEASED.

1. Drive Speed Switch/Torque Select

The switch has three positions. The forward position gives maximum drive speed. The back position gives maximum torque for rough terrain and climbing grades. The center position allows the machine to be driven as quietly as possible by leaving the engine at mid speed and the drive motors in maximum displacement.

WARNING

ONLY USE THE PLATFORM LEVELING OVERRIDE FUNCTION FOR SLIGHT LEVELING OF THE PLATFORM. INCORRECT USE COULD CAUSE THE LOAD/OCCUPANTS TO SHIFT OR FALL. FAILURE TO DO SO COULD RESULT IN DEATH OR SERIOUS INJURY.

2. Platform Leveling Override

A three position switch allows the operator to adjust the automatic self leveling system. This switch is used to adjust the platform level in situations such as ascending/descending a grade.

3. Horn

Supplies electrical power to an audible warning device when pressed.

4. Power/Emergency Stop

An on-off Power/Emergency Stop switch and a separate Engine Start/Auxiliary Power toggle switch on the platform console supply electrical power to the starter solenoid, when the ignition switch is placed in the ON position and the ENGINE START switch is push forward.

SECTION 3 - MACHINE CONTROLS AND INDICATORS

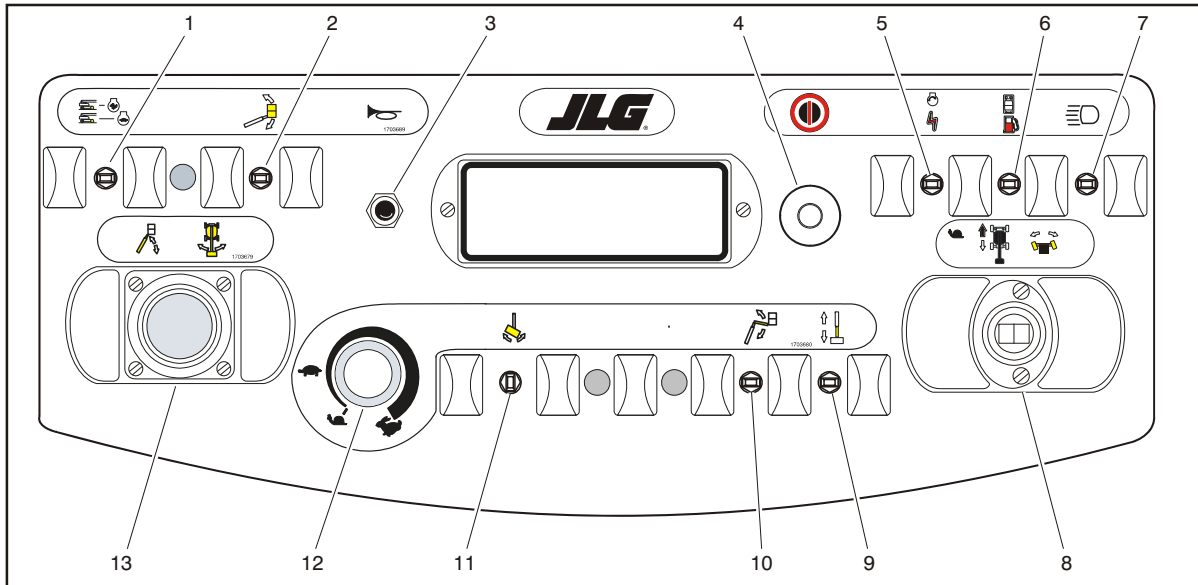

- | | | | |
|-------------------------------|--------------------|---------------------------|----------------------------|
| 1. Drive Speed/Torque Select | 5. Auxiliary Power | 9. Main Telescope Control | 13. Main Lift/Swing |
| 2. Platform Leveling Override | 6. Fuel Select | 10. Jib Lift | 14. Footswitch (Not Shown) |
| 3. Horn | 7. Lights | 11. Platform Rotate | |
| 4. Power/Emergency Stop | 8. Drive Steer | 12. Function Speed | |

Figure 3-5. Platform Control Console

SECTION 3 - MACHINE CONTROLS AND INDICATORS

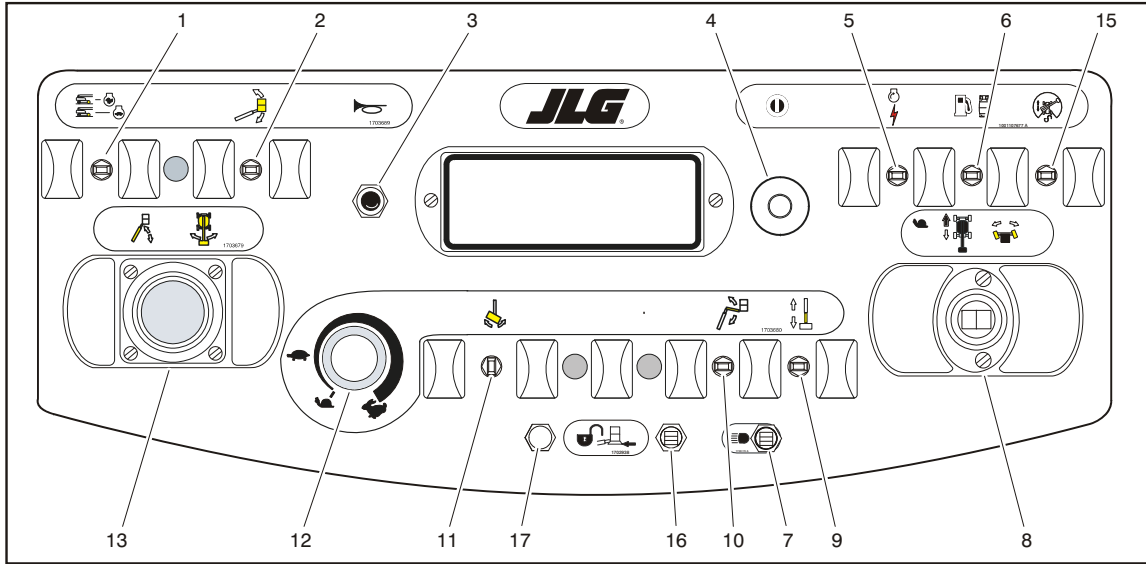

- | | | | |
|-------------------------------|---------------------------|---------------------|--------------------------------|
| 1. Drive Speed/Torque Select | 6. Fuel Select | 10. Jib Lift | 14. Footswitch (Not Shown) |
| 2. Platform Leveling Override | 7. Lights | 11. Platform Rotate | 15. Drive Orientation Override |
| 3. Horn | 8. Drive Steer | 12. Function Speed | 16. Soft Touch Override |
| 4. Power/Emergency Stop | 9. Main Telescope Control | 13. Main Lift/Swing | 17. Soft Touch Indicator |
| 5. Auxiliary Power | | | |

Figure 3-6. Platform Control Console - w/Drive Orientation

5. Auxiliary Power

Energizes the electrically operated pump, when actuated. (Switch must be held ON for duration of auxiliary pump use.)

The auxiliary pump functions to provide sufficient oil flow to operate the basic machine functions should the main pump or engine fail. The auxiliary pump will operate tower boom lift, tower telescope, main boom lift, main telescope and swing.

It should be noted that the functions will operate at a slower than normal rate because of the lower gpm delivered.

NOTICE

WHEN OPERATING ON AUXILIARY POWER, DO NOT OPERATE MORE THAN ONE FUNCTION AT THE SAME TIME. SIMULTANEOUS OPERATION CAN OVERLOAD THE AUXILIARY PUMP MOTOR.

NOTE: *The main function of auxiliary power is to lower the platform in the event of primary power failure. Determine the reason for primary power failure and have the problem corrected by a certified JLG service technician.*

6. Fuel Select (Dual Fuel Engine Only) (If Equipped)

Gasoline or liquid propane fuel may be selected by moving the switch to the appropriate position. It is unnecessary to purge the fuel system before switching fuels, so there is no waiting period when switching fuels while the engine is running.

7. Lights (If Equipped)

Operates control console panel lights and head lights if the machine is so equipped. The ignition switch does not have to be on to operate the lights, so care must be taken to avoid draining the battery if left unattended. The master switch and / or the ignition switch at the ground control will turn off power to all lights.

SECTION 3 - MACHINE CONTROLS AND INDICATORS

8. Drive/Steer.

Provides for driving either forward or backward. Push forward to drive forward, pull back to drive in reverse.

Steering is controlled by a thumb-activated rocker switch on top of the joystick.

NOTE: *Both drive and steer functions work in the opposite direction when the boom is positioned over front of the chassis.*

9. Main Telescope Control.

Allows extension and retraction of the main boom when positioned to in or out.

10. Articulating Jib Lift. (460SJ Only)

Push level, toggle switch forward to lift up, pull back to lift down.

11. Platform Rotate.

Allows the operator to rotate the basket to the left or right when positioned to the desired direction.



DO NOT OPERATE MACHINE IF DRIVE SPEED/TORQUE SELECT OR FUNCTION SPEED SWITCHES OPERATE WHEN BOOM IS ABOVE HORIZONTAL.

12. Function Speed.

Provides variable speed control of all boom functions grouped to the right of the knob. For smoothest operation of these functions, use two hands: rotate the knob counterclockwise to the slowest position, select the function switch, and while holding the switch on, rotate the knob to the desired speed. To achieve a smooth stop, rotate the knob ccw to a slow speed prior to letting go of the function switch.

Rotating the knob fully counterclockwise until a click is heard puts all controls, including drive, main lift, and swing into creep speed. This slow speed is used for fine positioning of the platform when close to obstacles. A snail symbol is used to indicate “creep” speed and is shown at the Function Speed knob as well as near the proportional controllers to act as a reminder.

SECTION 3 - MACHINE CONTROLS AND INDICATORS

NOTE: When boom is positioned above horizontal and any of the following switches, Drive Speed/torque Select or Function Speed, are positioned to High, high function speeds are automatically cut out and the machine continues to operate at a lower speed.

13. Main Lift/Swing Controller.

The dual axis joystick is provided for main lift and swing. Push forward to lift up, pull backward to lift down. Move right to swing right, move left to swing left. Moving the joystick activates switches to provide the functions selected. Proportional control of these functions can be attained by using the Function Speed knob.

NOTE: Main Lift, Swing, and Drive control levers are spring-loaded and will automatically return to neutral (off) position when released.

NOTE: Main lift and swing functions may be selected in combination. The handle features a round gate so that maximum speed is reduced when multiple functions are selected.

14. Footswitch (Not Shown).

This feature makes it necessary to depress the footswitch to allow operation of the platform controls.

WARNING

TO AVOID SERIOUS INJURY, DO NOT REMOVE, MODIFY OR DISABLE THE FOOTSWITCH BY BLOCKING OR ANY OTHER MEANS.

NOTICE

FOOTSWITCH MUST BE ADJUSTED SO THAT FUNCTIONS WILL OPERATE WHEN PEDAL IS APPROXIMATELY AT ITS CENTER OF TRAVEL. IF SWITCH OPERATES WITHIN LAST 1/4" OF TRAVEL, TOP OR BOTTOM, IT SHOULD BE ADJUSTED.

NOTE: For engine starting, the footswitch must be in the released (up) position. Footswitch must be actuated in order for the platform controls to function.

NOTE: These machines have a 7 second delay timer. If function has not been activated within 7 seconds after depressing the footswitch, recycle footswitch.

SECTION 3 - MACHINE CONTROLS AND INDICATORS

15. Drive Orientation Override

When the boom is swung over the rear tires or further in either direction, the Drive Orientation indicator will illuminate when the drive function is selected. Push and release the switch, and within 3 seconds move the Drive/Steer control to activate drive or steer. Before driving, locate the black/white orientation arrows on both the chassis and the platform controls. Move the drive controls in a direction matching the directional arrows.

16. Soft Touch Override Switch (If equipped)

Enables the functions that were cut out by the Soft Touch system to operate again at creep speed, allowing the operator to move the platform away from the obstacle that caused the shutdown situation.

17. Soft Touch Indicator (If Equipped)

Indicates the Soft Touch bumper is against an object. All controls are cut out until the override button is pushed, at which time controls are active in the Creep Mode.

Platform Control Indicator Panel

(See Figure 3-7., Platform Control Indicator Panel) and Figure 3-8., Platform Control Indicator Panel - w/Drive Orientation.

1. Tilt Alarm Warning Light and Alarm

This orange illuminator indicates that the chassis is on a slope. An alarm will also sound when the chassis is on a slope and the boom is above horizontal. If lit when boom is raised or extended, retract and lower to below horizontal then reposition machine so that it is level before continuing operation. If the boom is above horizontal and the machine is on a slope, the tilt alarm warning light will illuminate and an alarm will sound and CREEP is automatically activated.

WARNING

IF TILT WARNING LIGHT IS ILLUMINATED WHEN BOOM IS RAISED OR EXTENDED, RETRACT AND LOWER TO BELOW HORIZONTAL THEN REPOSITION MACHINE SO THAT IT IS LEVEL BEFORE EXTENDING BOOM OR RAISING BOOM ABOVE HORIZONTAL.

2. Platform Overload (If equipped)

Indicates the platform has been overloaded.

SECTION 3 - MACHINE CONTROLS AND INDICATORS

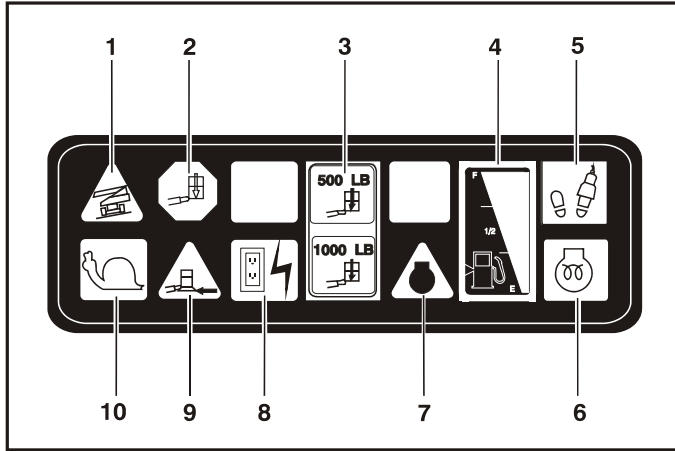

- | | |
|----------------------|-----------------|
| 1. Tilt | 6. Glow Plug |
| 2. Platform Overload | 7. Malfunction |
| 3. Capacity | 8. Generator |
| 4. Fuel Level | 9. Soft Touch |
| 5. Enable | 10. Creep Speed |

Figure 3-7. Platform Control Indicator Panel

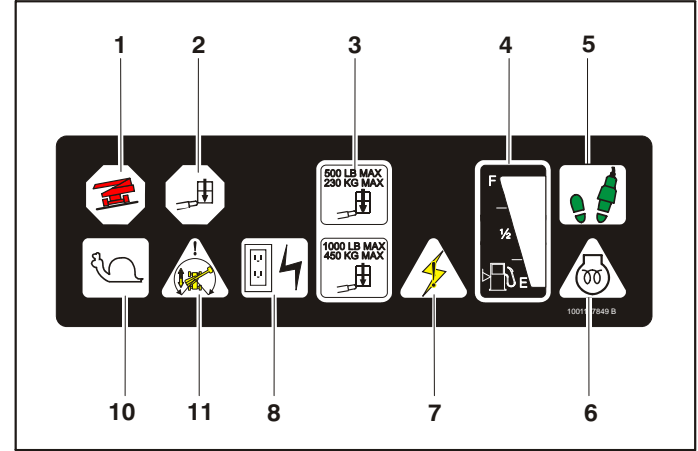

- | | |
|----------------------|-----------------------|
| 1. Tilt | 7. Malfunction |
| 2. Platform Overload | 8. Generator |
| 3. Capacity | 9. Not Used |
| 4. Fuel Level | 10. Creep Speed |
| 5. Enable | 11. Drive Orientation |
| 6. Glow Plug | |

**Figure 3-8. Platform Control Indicator Panel - w/
Drive Orientation**

SECTION 3 - MACHINE CONTROLS AND INDICATORS

3. Capacity Indicator

Indicates the maximum capacity for the current position of the platform.

4. Fuel Indicator

Indicates level of fuel in the tank. When fuel level indicates 1/8 full or less, there is approximately four usable gallons of fuel remaining.

5. Enable Indicator

Indicates that the footswitch is depressed and the platform controls are ready for use. To enable the controls, depress the footswitch and select any function within seven seconds. The controls will then remain active as long as there is not a delay of seven seconds between stopping one function and starting the next one. If the seven second interval is exceeded, the enable light will go out and the controls will not operate. To enable the controls again, remove your foot from the footswitch and depress the footswitch.

6. Glow Plug Indicator

Illuminates when the glow plugs are operating. Wait until the light goes out before cranking engine.

7. Malfunction Indicator

On machines prior to S/N 61718, the light turns on and an alarm sounds when machine's power system requires immediate service. Any of the following conditions will turn on light and alarm: low engine oil pressure, high engine coolant temperature, clogged engine air filter, low alternator output, clogged hydraulic oil return filter, or clogged charge pump filter.

On machines from S/N 61718 to present, the light indicates that the Control System has detected a malfunction and a Diagnostic Trouble Code has been set in the system memory. Refer to the Service Manual for instructions concerning the trouble codes and trouble code retrieval.

The malfunction indicator light will illuminate for 2-3 seconds when the key is positioned to the on position to act as a self test.

SECTION 3 - MACHINE CONTROLS AND INDICATORS

8. AC Generator (If Equipped)

When illuminated (Green), indicates the generator is in operation.

9. Soft Touch Indicator (If Equipped)

When illuminated (Yellow), indicates the Soft Touch bumper is against an object. All controls are cut out until the override button is pushed, at which time controls are active in the Creep mode.

10. Creep Speed Indicator

Illuminated (Green) when the Function Speed Control is turned to the creep position, the indicator acts as a reminder that all functions are set to the slowest speed.

11. Drive Orientation Indicator

When the boom is swung beyond the rear drive tires or further in either direction, the Drive Orientation indicator will illuminate when the drive function is selected. This is a signal for the operator to verify that the drive control is being operated in the proper direction (i.e. controls reversed situations).

SECTION 3 - MACHINE CONTROLS AND INDICATORS

 **NOTES:**

<hr/>	<hr/>
<hr/>	<hr/>
<hr/>	<hr/>
<hr/>	<hr/>
<hr/>	<hr/>
<hr/>	<hr/>
<hr/>	<hr/>
<hr/>	<hr/>
<hr/>	<hr/>
<hr/>	<hr/>
<hr/>	<hr/>
<hr/>	<hr/>
<hr/>	<hr/>
<hr/>	<hr/>
<hr/>	<hr/>
<hr/>	<hr/>
<hr/>	<hr/>
<hr/>	<hr/>
<hr/>	<hr/>
<hr/>	<hr/>
<hr/>	<hr/>
<hr/>	<hr/>

SECTION 4. MACHINE OPERATION

4.1 DESCRIPTION

This machine is a self-propelled hydraulic personnel lift equipped with a work platform on the end of an elevating and rotating boom.

The primary operator control station is in the platform. From this control station, the operator can drive and steer the machine in both forward and reverse directions. The operator can raise or lower the main or tower boom or swing the boom to the left or right. Standard boom swing is 360 degree continuous left and right of the stowed position. The machine has a Ground Control Station which will override the Platform Control Station. Ground Controls operate Boom Lift and Swing, and are to be used in an emergency to lower the platform to the ground should the operator in the platform be unable to do so.

4.2 OPERATING CHARACTERISTICS AND LIMITATIONS

Capacities

Raising boom above horizontal and/or extension of boom beyond retracted position with or without any load in platform, is based on the following criteria:

1. Machine is positioned on a smooth, firm and level surface.
2. Load is within manufacturer's rated design capacity.
3. All machine systems are functioning properly.
4. Proper tire pressure exists in the tires.
5. Machine is as originally equipped from JLG.

SECTION 4 - MACHINE OPERATION

Stability

This machine as originally manufactured by JLG Industries Inc., when operated within its rated capacity on a smooth, firm and level supporting surface, and in accordance with the instructions provided on the machine and this manual, provides a stable machine for all platform positions.

Machine stability is based on two positions which are called FORWARD STABILITY and BACKWARD STABILITY. The machines position of least backward stability is shown in Figure 4-1., and its position of least forward stability is shown in Figure 4-2.

⚠ WARNING

TO AVOID FORWARD OR BACKWARD UPSET, DO NOT OVERLOAD MACHINE OR OPERATE ON AN OUT-OF-LEVEL SURFACE.

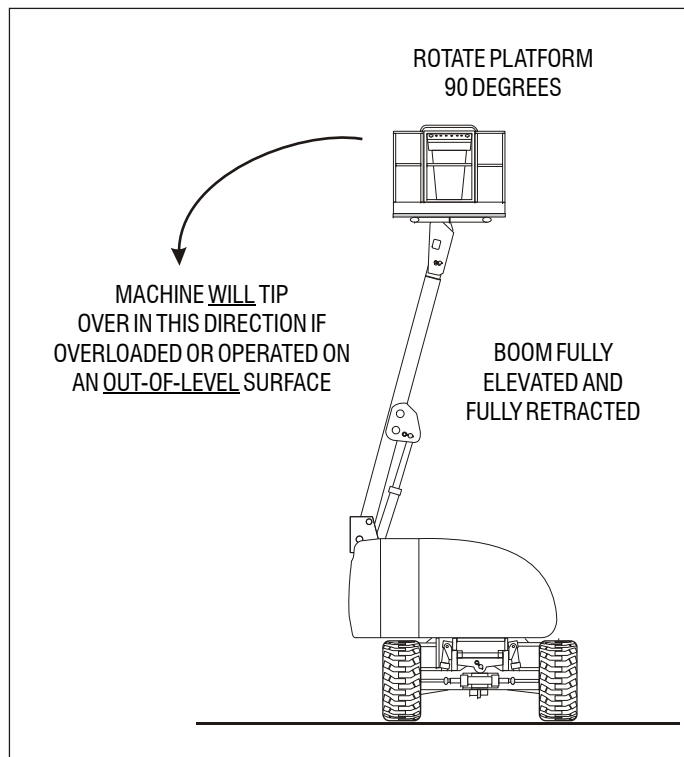

Figure 4-1. Position Of Least Backward Stability

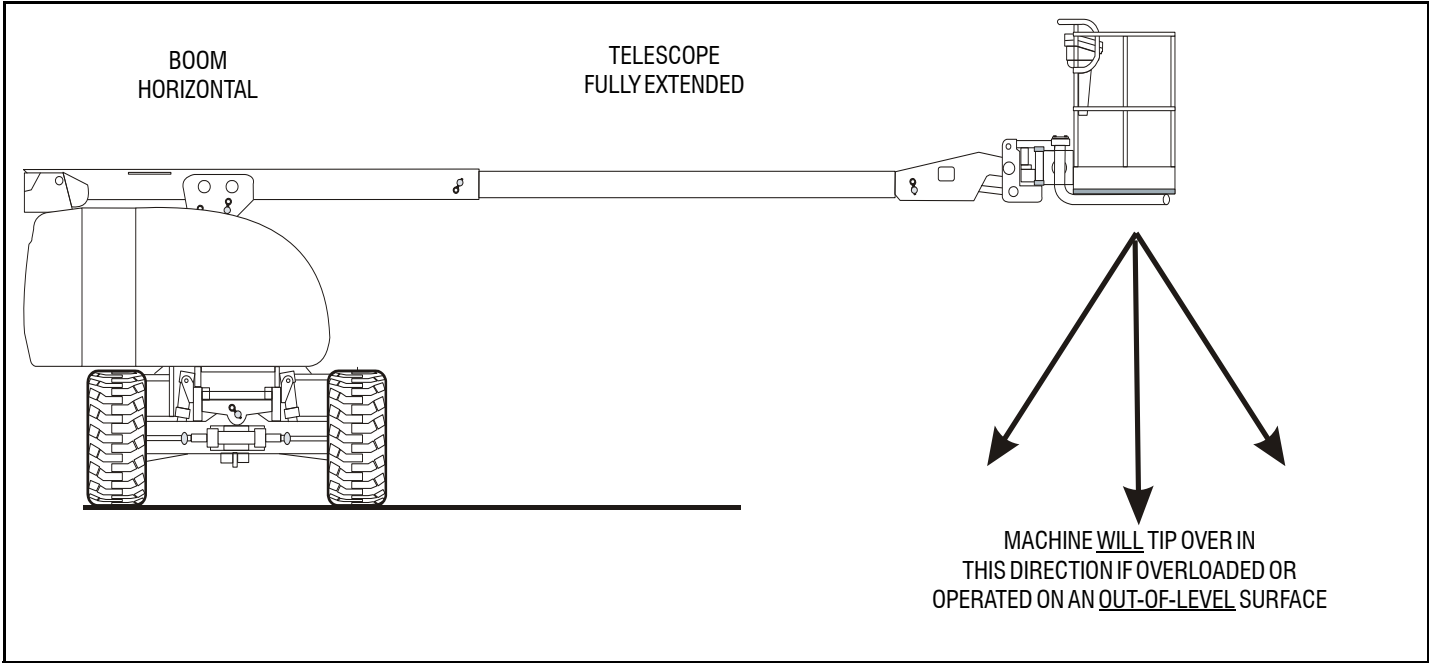

Figure 4-2. Position Of Least Forward Stability

4.3 ENGINE OPERATION

NOTE: Initial starting should always be performed from the Ground Control station.

Starting Procedure

1. Check engine oil. If necessary, add oil in accordance with the Engine Manufacturer's manual.
2. Check fuel level. Add fuel if necessary.
3. Check that air cleaner components are in place and securely fastened.

CAUTION

IF ENGINE FAILS TO START PROMPTLY, DO NOT CRANK FOR AN EXTENDED PERIOD. SHOULD ENGINE FAIL TO START ONCE AGAIN, ALLOW STARTER TO "COOL OFF" FOR 2-3 MINUTES. IF ENGINE FAILS AFTER SEVERAL ATTEMPTS, REFER TO ENGINE MAINTENANCE MANUAL.

NOTE: Machines with diesel engines, after turning on ignition, operator must wait until glow plug indicator light goes out before cranking engine.

4. Turn key of SELECT switch to GROUND. Position POWER/EMERGENCY STOP switch to ON, then push the ENGINE START switch to the upward position until engine starts.

CAUTION

ALLOW ENGINE TO WARM-UP FOR A FEW MINUTES AT LOW SPEED BEFORE APPLYING ANY LOAD.

5. After engine has had sufficient time to warm up, shut engine off.

6. Turn key of SELECT switch to PLATFORM.
7. From Platform position POWER/EMERGENCY STOP switch to ON, then push the ENGINE START switch to the forward position until engine starts.

NOTE: Footswitch must be in released (up) position before starter will operate. If starter operates with footswitch in the depressed position, DO NOT OPERATE MACHINE.

Shutdown Procedure

CAUTION

IF AN ENGINE MALFUNCTION NECESSITATES UNSCHEDULED SHUTDOWN, DETERMINE AND CORRECT CAUSE BEFORE RESUMING ANY OPERATION.

1. Remove all load and allow engine to operate at low speed setting for 3-5 minutes; this allows for further reduction of internal engine temperature.
2. Position POWER/EMERGENCY STOP switch to OFF.
3. Turn key of MASTER switch to OFF position.

NOTE: Refer to Engine Manufacturer's manual for detailed information.

4.4 TRAVELING (DRIVING)

See Figure 4-3., Grades and Sideslopes

WARNING

DO NOT DRIVE WITH BOOM EXTENDED OR ABOVE HORIZONTAL EXCEPT ON A SMOOTH, FIRM AND LEVEL SURFACE.

DO NOT DRIVE WITH HOODS RAISED OR UNLATCHED.

TO AVOID LOSS OF TRAVEL CONTROL OR UPSET ON GRADES AND SIDESLOPES, DO NOT DRIVE MACHINE ON GRADES OR SIDESLOPES EXCEEDING THOSE SPECIFIED ON MACHINE INFORMATION PLACARD ON THE LEFT SIDE OF THE FRAME.

SECTION 4 - MACHINE OPERATION

⚠ WARNING

TRAVEL GRADES WITH DRIVE SPEED/TORQUE SELECT SWITCH IN THE FORWARD POSITION. USE EXTREME CAUTION WHEN DRIVING IN REVERSE AND AT ALL TIMES WHEN DRIVING WITH PLATFORM ELEVATED AND ESPECIALLY WHEN DRIVING WITH ANY PART OF MACHINE WITHIN 6 FEET (2 M) OF AN OBSTRUCTION. DO NOT USE DRIVE TO MANEUVER PLATFORM CLOSE TO AN OBSTRUCTION...USE ONE OF THE BOOM FUNCTIONS.

BEFORE DRIVING, LOCATE THE BLACK/WHITE ORIENTATION ARROWS ON BOTH THE CHASSIS AND THE PLATFORM CONTROLS. MOVE THE DRIVE CONTROLS IN A DIRECTION MATCHING THE DIRECTIONAL ARROWS.

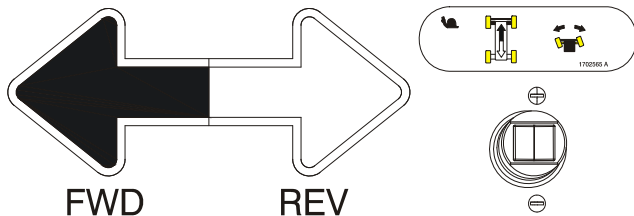

Traveling is limited by two factors:

1. Gradeability, which is the percent of grade of the incline the machine can climb.
2. Sideslope, which is the angle of the slope the machine can be driven across.

When the boom is raised or extended, the machine should not be operated on grades or sideslopes that are greater than that detected by the tilt alarm. The tilt alarm will sound to alert the operator when the machine is on an unsafe slope. The machines high drive function will also be cut back to low drive.

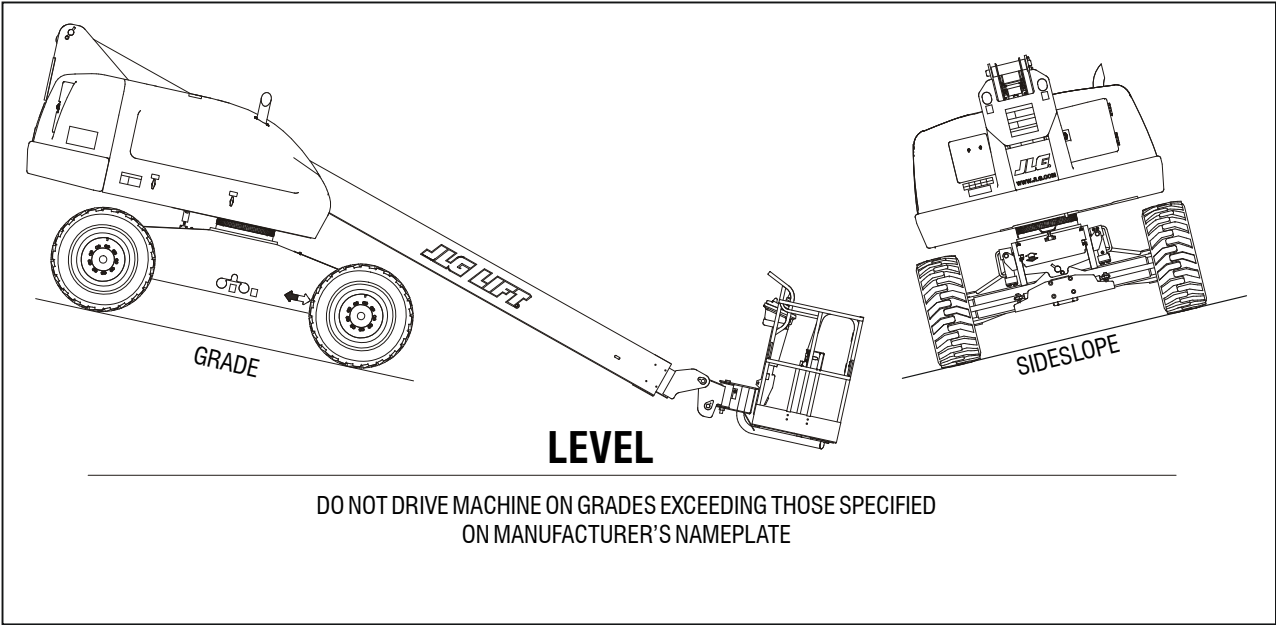

Figure 4-3. Grades and Sideslopes

SECTION 4 - MACHINE OPERATION

Traveling Forward or Reverse

1. With engine running, depress footswitch and position DRIVE control to FORWARD and hold for the duration of forward travel desired.

NOTE: *When DRIVE or STEER functions are being operated there is an interlock which prevents operation of boom functions.*

2. Depress footswitch and position DRIVE control to REVERSE and hold for duration of reverse travel desired.
3. Depress footswitch and position STEER control to RIGHT for traveling right and LEFT for traveling left.
4. To obtain maximum travel speed, position the DRIVE controller to FAST and activate the following switches: Position DRIVE SPEED/TORQUE SELECT switch to FAST. (Forward Position)
5. Prior to stopping the machine, position switches as follows:
Position DRIVE SPEED/TORQUE SELECT switch to LOW. (Backward Position)

6. For traveling up grades, position switches as follows:
Position DRIVE SPEED/TORQUE SELECT switch to HIGH.

NOTE: *For smoother operation when driving with fully extended boom, place DRIVE control to SLOW before stopping.*

This machine is equipped with a Drive Orientation Indicator. The yellow light on the platform control console indicates that the boom is swung beyond the rear drive tires and the machine may Drive/Steer in the opposite direction from the movement of the controls. If the indicator is illuminated, operate the Drive function in the following manner:

1. Match the black and white direction arrows on both platform control panel and the chassis to determine the direction the machine will travel.
2. Push and release the Drive Orientation Override switch. Within 3 seconds, slowly move the Drive control toward the arrow matching the intended direction of machine travel. The indicator light will flash during the 3 second interval until the drive function is selected.

4.5 STEERING

Depress footswitch to steer machine, push on the left side of the switch to steer left, on the right side to steer right.

CAUTION

BEFORE OPERATING MACHINE, MAKE SURE BOOM IS POSITIONED OVER REAR AXLE. IF BOOM IS OVER FRONT AXLE (STEER WHEELS), STEER AND DRIVE CONTROLS WILL MOVE IN OPPOSITE DIRECTION THAN INDICATED ON MACHINE PLACARDS.

4.6 PARKING AND STOWING

Park and stow machine as follows:

1. Park machine in travel position; boom lowered over rear, all access panels and doors closed and secured, ignition off.
2. Check that brakes hold machine in position.
3. Chock wheels front and rear.
4. Turn off SELECT switch and remove key.

4.7 PLATFORM

Loading from Ground Level

1. Position chassis on a smooth, firm and level surface.
2. If total load (personnel, tools, and supplies) is less than rated capacity, distribute load uniformly on platform floor, and proceed to work position.

Loading From Positions Above Ground Level

Before loading weight to platform above ground level:

1. Determine what the total rated capacity weight will be after additional weight is loaded (personnel, tools and supplies).
2. If total weight in platform will be less than rated capacity, proceed with adding weight.

Platform Level Adjustment

⚠ WARNING

ONLY USE THE PLATFORM LEVELING OVERRIDE FUNCTION FOR SLIGHT LEVELING OF THE PLATFORM. INCORRECT USE COULD CAUSE THE LOAD/OCCUPANTS TO SHIFT OR FALL. FAILURE TO DO SO COULD RESULT IN DEATH OR SERIOUS INJURY.

This switch is used to adjust the platform level in situations such as ascending/descending a grade. To Level Up or Down - Position the Platform/Level control switch Up or Down and hold until the platform is level.

Platform Rotation

1. Depress footswitch to rotate platform to the left, PLATFORM ROTATE control is positioned to the LEFT and held until desired position is reached.
2. Depress footswitch to rotate platform to the right, PLATFORM ROTATE control is positioned to the RIGHT and held until desired position is reached.

4.8 BOOM

⚠ WARNING

A TILT WARNING LIGHT IS LOCATED ON THE CONTROL CONSOLE WHICH LIGHTS WHEN THE CHASSIS IS ON A 5 DEGREE OR GREATER SLOPE. DO NOT SWING OR RAISE BOOM ABOVE HORIZONTAL WHEN LIGHT IS LIT.

DO NOT DEPEND ON TILT ALARM AS A LEVEL INDICATOR FOR THE CHASSIS. THE TILT ALARM INDICATES THE CHASSIS IS ON A SEVERE SLOPE (5 DEGREE OR GREATER). CHASSIS MUST BE LEVEL BEFORE SWINGING, OR RAISING BOOM ABOVE HORIZONTAL.

TO AVOID MACHINE UPSET IF THE TILT WARNING LIGHT ILLUMINATED WHEN THE BOOM IS RAISED ABOVE HORIZONTAL, LOWER THE PLATFORM TO GROUND LEVEL, THEN REPOSITION MACHINE SO THAT CHASSIS IS LEVEL BEFORE RAISING BOOM.

TRAVELING WITH BOOM BELOW HORIZONTAL IS PERMITTED ON GRADES AND SIDE SLOPES SPECIFIED ON SERIAL NUMBER PLACARD.

TO AVOID SERIOUS INJURY, DO NOT OPERATE MACHINERY IF ANY CONTROL LEVER OR TOGGLE SWITCH CONTROLLING PLATFORM MOVEMENT DOES NOT RETURN TO THE "OFF" POSITION WHEN RELEASED.

TO AVOID A COLLISION AND INJURY IF PLATFORM DOES NOT STOP WHEN A CONTROL SWITCH OR LEVER IS RELEASED, REMOVE FOOT FROM FOOTSWITCH OR USE EMERGENCY STOP SWITCH TO STOP MACHINE.

Swinging the Boom

Depress footswitch to swing boom, with footswitch activated, position SWING control switch to RIGHT or LEFT for direction desired.

NOTICE

WHEN SWINGING THE BOOM MAKE SURE THERE IS AMPLE ROOM FOR THE BOOM TO CLEAR SURROUNDING WALLS, PARTITIONS AND EQUIPMENT.

Raising and Lowering the Main Boom

NOTE: *Lift up will not function when the boom is near full elevation and the platform is out of level.*

To raise or lower the Main Boom, with footswitch activated, position Main Boom Lift lever to UP or DOWN until desired height is reached.

Telescoping the Main Boom

To extend or retract the main boom, with the footswitch activated, position the Main Telescope Control Switch to the in or out position and hold until the platform reaches the desired position.

4.9 AUXILIARY POWER - NON ADE EQUIPPED MACHINES

CAUTION

WHEN OPERATING ON AUXILIARY POWER, DO NOT OPERATE MORE THAN ONE FUNCTION AT A TIME. (SIMULTANEOUS OPERATION CAN OVERLOAD THE 12-VOLT AUXILIARY PUMP MOTOR.)

A toggle type auxiliary power control switch is located on the platform control station and another is located on the ground control station. Operation of either switch turns on the electrically driven auxiliary hydraulic pump. This should be used in case of failure of the main power plant. The auxiliary pump will operate boom lift, telescope and swing. To activate auxiliary power:

Activating from the Platform Control Station

1. Position PLATFORM/GROUND SELECT KEY SWITCH to PLATFORM.
2. Position POWER/EMERGENCY STOP switch to ON.
3. Depress and hold footswitch.
4. Operate appropriate control switch, lever or controller for desired function and hold.

5. Position AUXILIARY POWER switch to ON and hold.
6. Release AUXILIARY POWER switch, selected control switch, lever or controller, and footswitch.
7. Position POWER/EMERGENCY STOP switch to OFF.

Activating from the Ground Control Station

1. Position PLATFORM/GROUND SELECT KEY SWITCH to GROUND.
2. Position POWER/EMERGENCY STOP switch to ON.
3. Operate appropriate control switch or controller for desired function and hold.
4. Position AUXILIARY POWER switch to ON and hold.
5. Release AUXILIARY POWER switch, and appropriate control switch or controller.
6. Position POWER/EMERGENCY STOP switch to OFF.

4.10 AUXILIARY POWER - ADE EQUIPPED MACHINES

⚠ CAUTION

WHEN OPERATING ON AUXILIARY POWER, DO NOT OPERATE MORE THAN ONE FUNCTION AT A TIME. (SIMULTANEOUS OPERATION CAN OVERLOAD THE 12-VOLT AUXILIARY PUMP MOTOR.)

A toggle type auxiliary power control switch is located on the platform control station and another is located on the ground control station. Operation of either switch turns on the electrically driven auxiliary hydraulic pump. This should be used in case of failure of the main power plant. The auxiliary pump will operate boom lift, telescope and swing. To activate auxiliary power:

Activating from the Platform Control Station

1. Position PLATFORM/GROUND SELECT KEY SWITCH to PLATFORM.
2. Position POWER/EMERGENCY STOP switch to ON.
3. Depress and hold footswitch.
4. Position AUXILIARY POWER switch to ON and hold.

5. Operate appropriate control switch, lever or controller for desired function and hold.
6. Release AUXILIARY POWER switch, selected control switch, lever or controller, and footswitch.
7. Position POWER/EMERGENCY STOP switch to OFF.

Activating from the Ground Control Station

1. Position PLATFORM/GROUND SELECT KEY SWITCH to GROUND.
2. Position POWER/EMERGENCY STOP switch to ON.
3. Position AUXILIARY POWER switch to ON and hold.
4. Operate appropriate control switch or controller for desired function and hold.
5. Release AUXILIARY POWER switch, and appropriate control switch or controller.
6. Position POWER/EMERGENCY STOP switch to OFF.

4.11 SHUT DOWN AND PARK

1. Drive machine to a protected area.
2. Assure main boom is fully retracted and lowered over rear (Drive) axle; all access panels and doors closed and secured.
3. Remove all load and allow engine to operate 3-5 minutes at LOW setting to permit reduction of engine internal temperatures.
4. At Ground Controls, turn KEY SELECT switch to (center) OFF. Position, POWER/EMERGENCY STOP switch (down) to OFF. Remove key.
5. Cover Platform Control console to protect instruction placards, warning decals and operating controls from hostile environment.

4.12 TIE DOWN AND LIFTING

The weight of the machine is stamped on the serial number plate. If the plate is missing or illegible, call JLG Industries or weigh the individual unit to find out the Gross Vehicle Weight.

When transporting machine, boom must be in the stowed mode and machine securely tied down to truck or trailer deck. Four tie down eyes are provided in the frame slab, one at each corner of the machine. Lock turntable before traveling long distances or before hauling machine on a truck or trailer.

If it becomes necessary to lift the machine using an overhead or mobile crane, it is very important that the lifting devices are attached only to the designated lifting area. (See Figure 4-6 Lifting and Tie Down Decal)

NOTE: *Tie down eyes are provided at the front, center, and rear in the frame slab. Lifting eyes are located in plate mounted on machine front at boom pivot. (See Figure 4-6 Lifting and Tie Down Decal)*

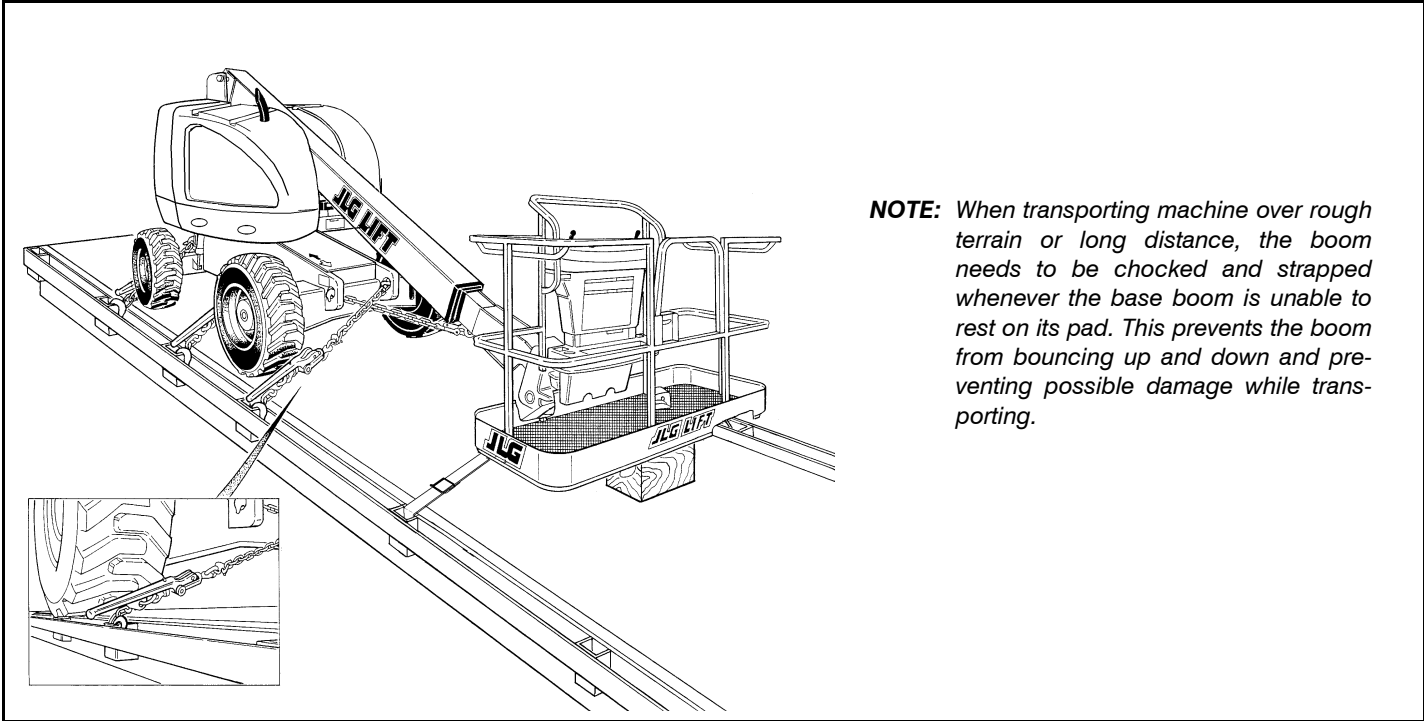

NOTE: When transporting machine over rough terrain or long distance, the boom needs to be chocked and strapped whenever the base boom is unable to rest on its pad. This prevents the boom from bouncing up and down and preventing possible damage while transporting.

Figure 4-4. Machine Tie Down - 400S Models

SECTION 4 - MACHINE OPERATION

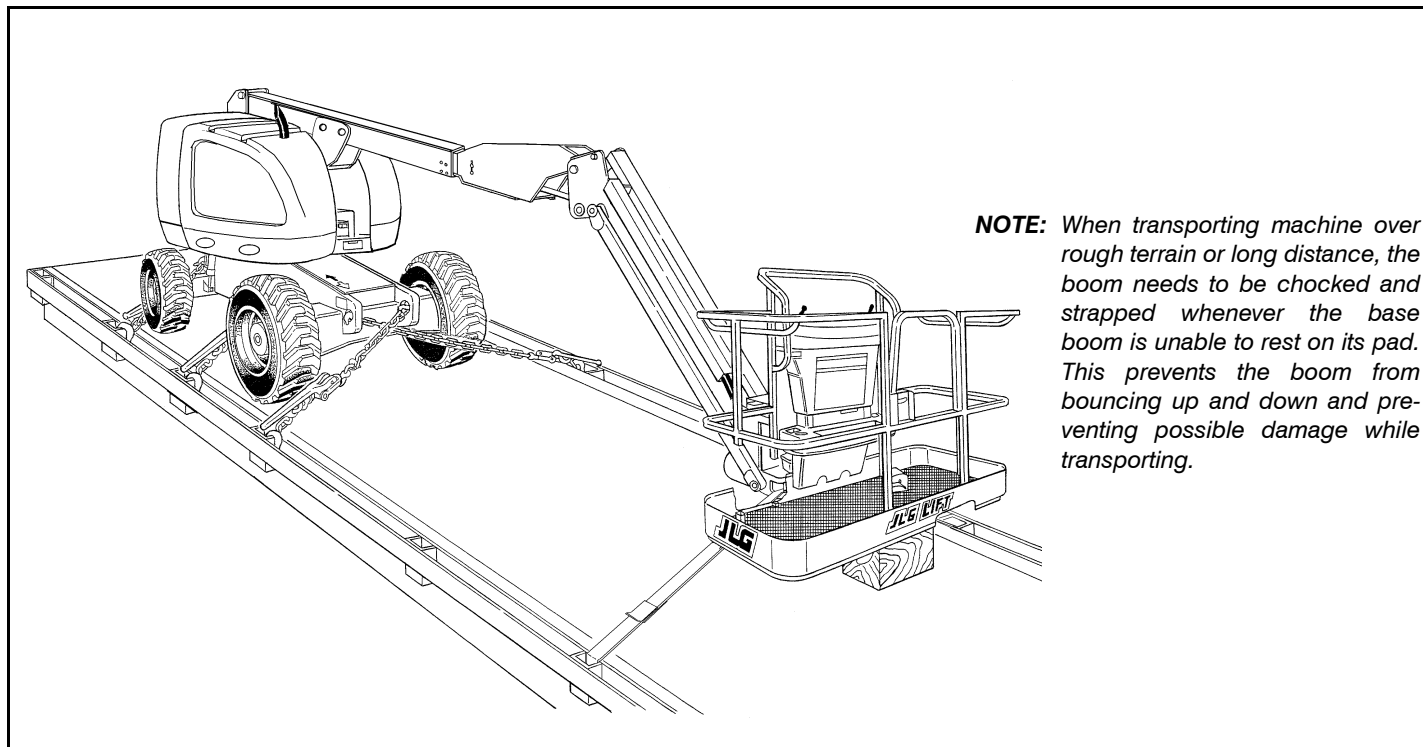

NOTE: When transporting machine over rough terrain or long distance, the boom needs to be chocked and strapped whenever the base boom is unable to rest on its pad. This prevents the boom from bouncing up and down and preventing possible damage while transporting.

Figure 4-5. Machine Tie Down - 460SJ Models

IMPORTANT

LIFTING INSTRUCTIONS

- 1. See the Operators and Safety Manual for approximate gross weight of machine as originally manufactured.
- 2. Place boom in the stowed position with turntable locked.
- 3. Remove all loose items from machine.
- 4. Properly adjust rigging to prevent damage to machine and so machine remains level.

TIE DOWN INSTRUCTIONS

- 1. Place boom in the stowed position with turntable locked.
- 2. Remove all loose items from machine.
- 3. Secure the chassis and the platform using straps or chains of adequate strength.

Refer to the Operators and Safety Manual for more information.

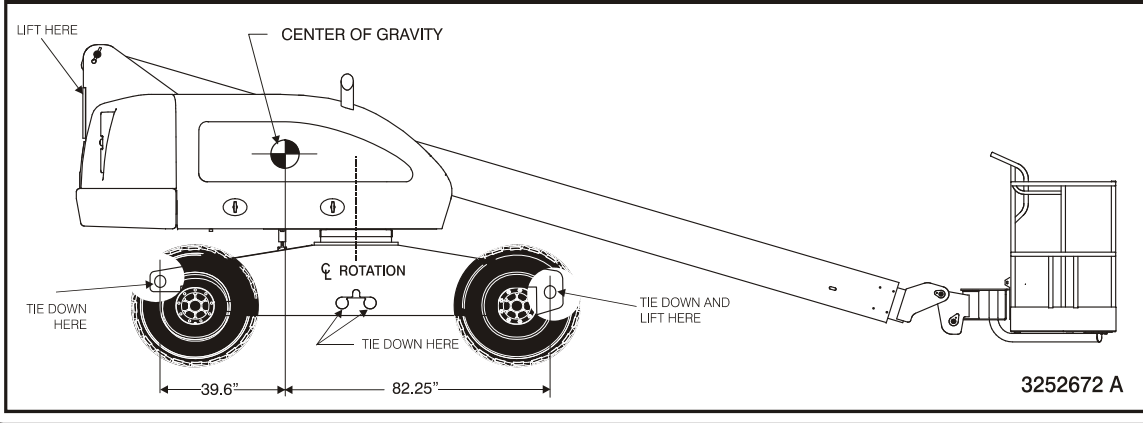

Figure 4-6. Lifting and Tie Down

SECTION 4 - MACHINE OPERATION

4.13 TOWING

⚠ WARNING

RUNAWAY VEHICLE/MACHINE HAZARD. MACHINE HAS NO TOWING BRAKES. TOWING VEHICLE MUST BE ABLE TO CONTROL MACHINE AT ALL TIMES. ON-HIGHWAY TOWING NOT PERMITTED. FAILURE TO FOLLOW INSTRUCTIONS COULD CAUSE SERIOUS INJURY OR DEATH.

MAXIMUM TOWING SPEED 5 M.P.H. (8 KM/H.) FOR NO LONGER THAN 30-45 MINUTES.

MAXIMUM TOWING GRADE 25%.

Prior to towing the machine, complete the following:

⚠ CAUTION

DO NOT TOW MACHINE WITH ENGINE OPERATING OR DRIVE HUBS ENGAGED.

1. Retract, lower and position boom over rear drive wheels in line with direction of travel.
2. Disconnect drive hubs by inverting the disconnect cap. (See Figure 4-7.) After towing the machine, complete the following:

3. Reconnect drive hubs by inverting the disconnect cap. (See Figure 4-7.)

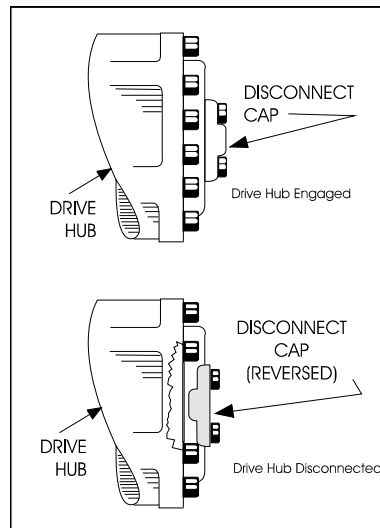

Figure 4-7. Drive Disconnect Hub

4.14 PLACARDS AND DECALS

Read and understand all placards and decals. Do not operate any machine on which DANGER, WARNING, CAUTION OR INSTRUCTION PLACARDS OR DECALS ARE MISSING OR ILLEGIBLE. Replace placards and decals if damaged, missing or illegible.

Decals are made with a Pressure Sensitive Adhesive on the back with a protective film on the front. Remove the damaged decal and thoroughly clean surface before installing a new decal. Simply peel off the back, and press new decal onto surface and remove the protective film.

NOTE: *Placards and Decals can be ordered by using part numbers located by each placard or decal.*

SECTION 4 - MACHINE OPERATION

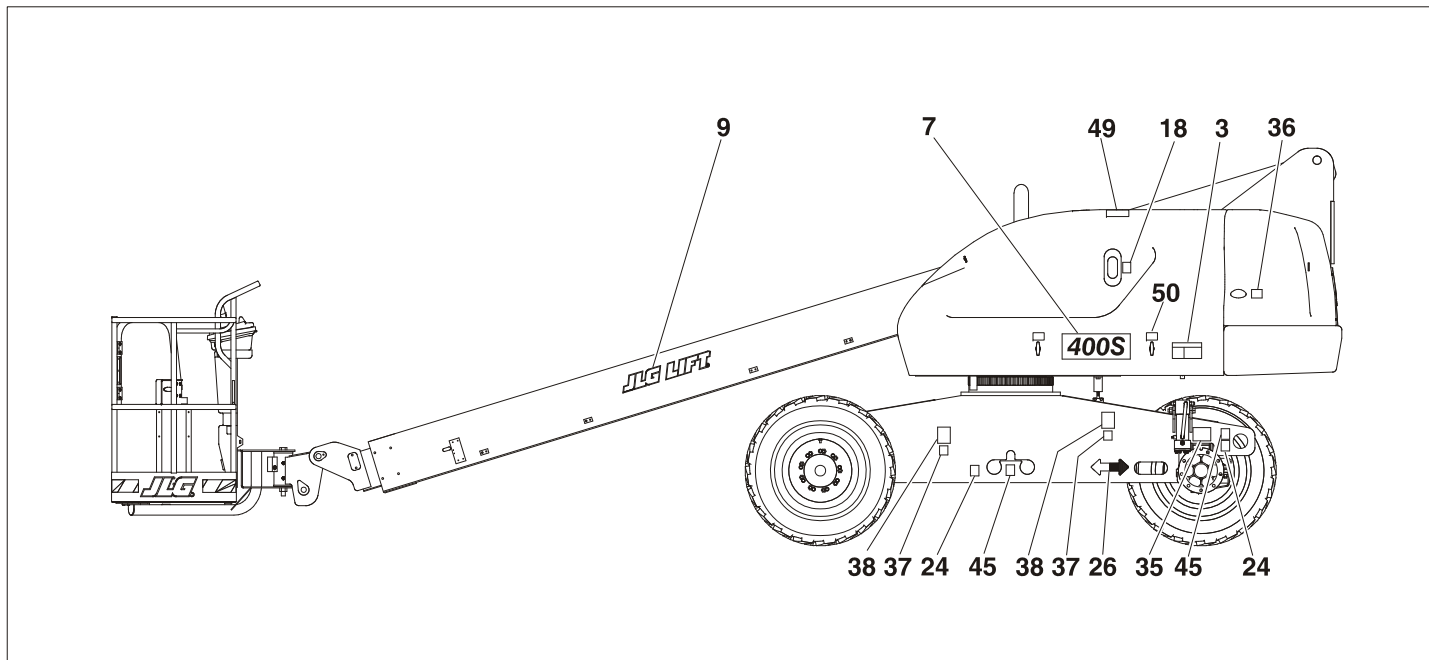

Figure 4-8. Decal Installation - Sheet 1 of 4

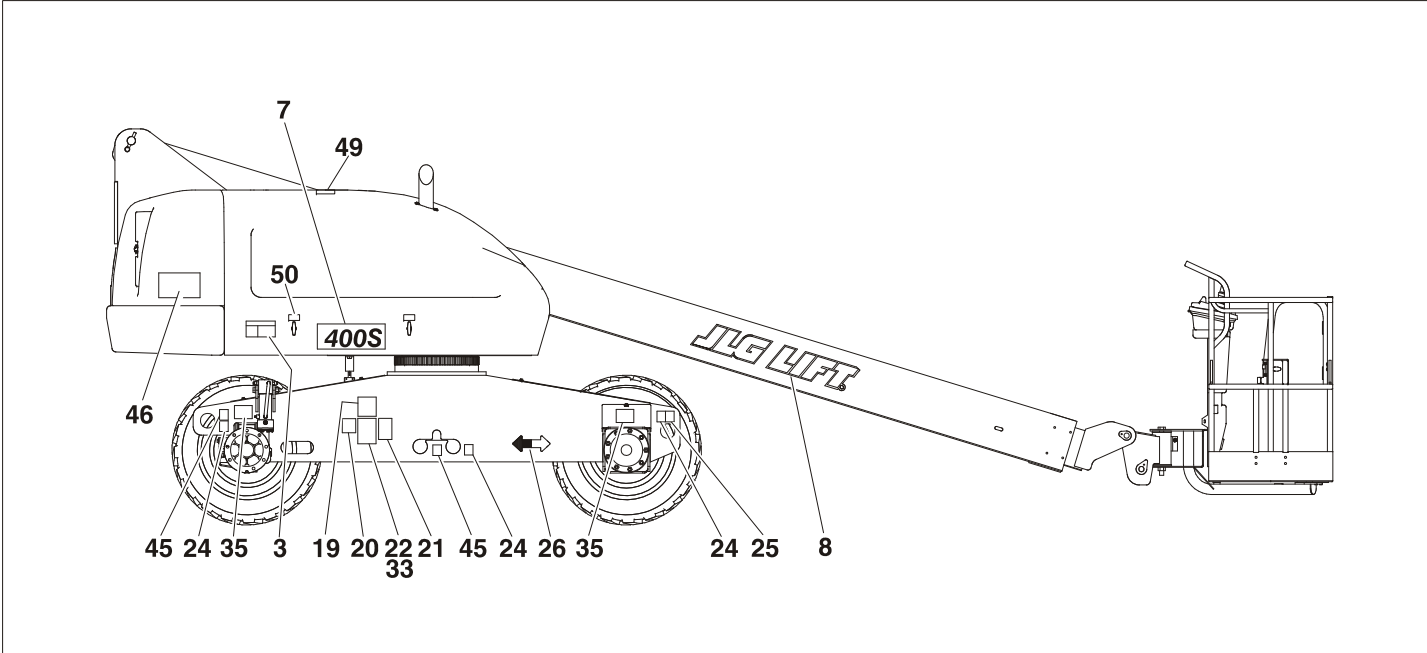

Figure 4-9. Decal Installation - Sheet 2 of 4

SECTION 4 - MACHINE OPERATION

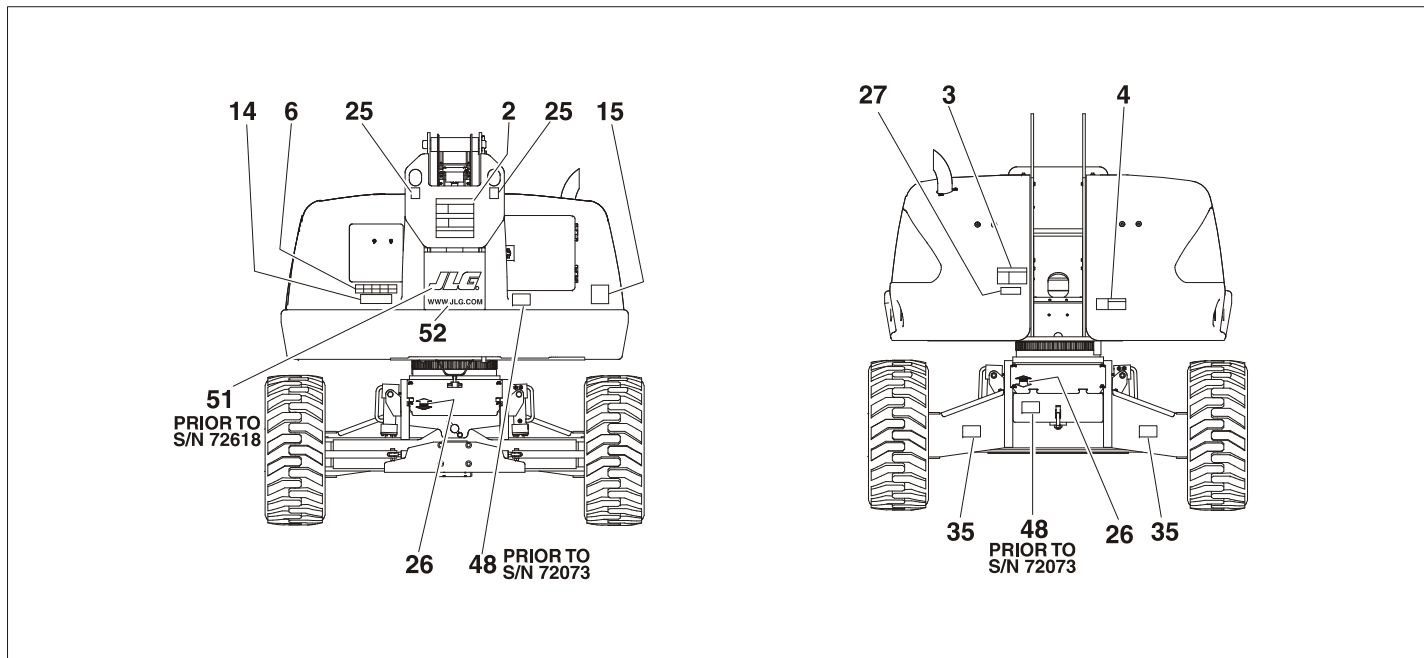

Figure 4-10. Decal Installation - Sheet 3 of 4

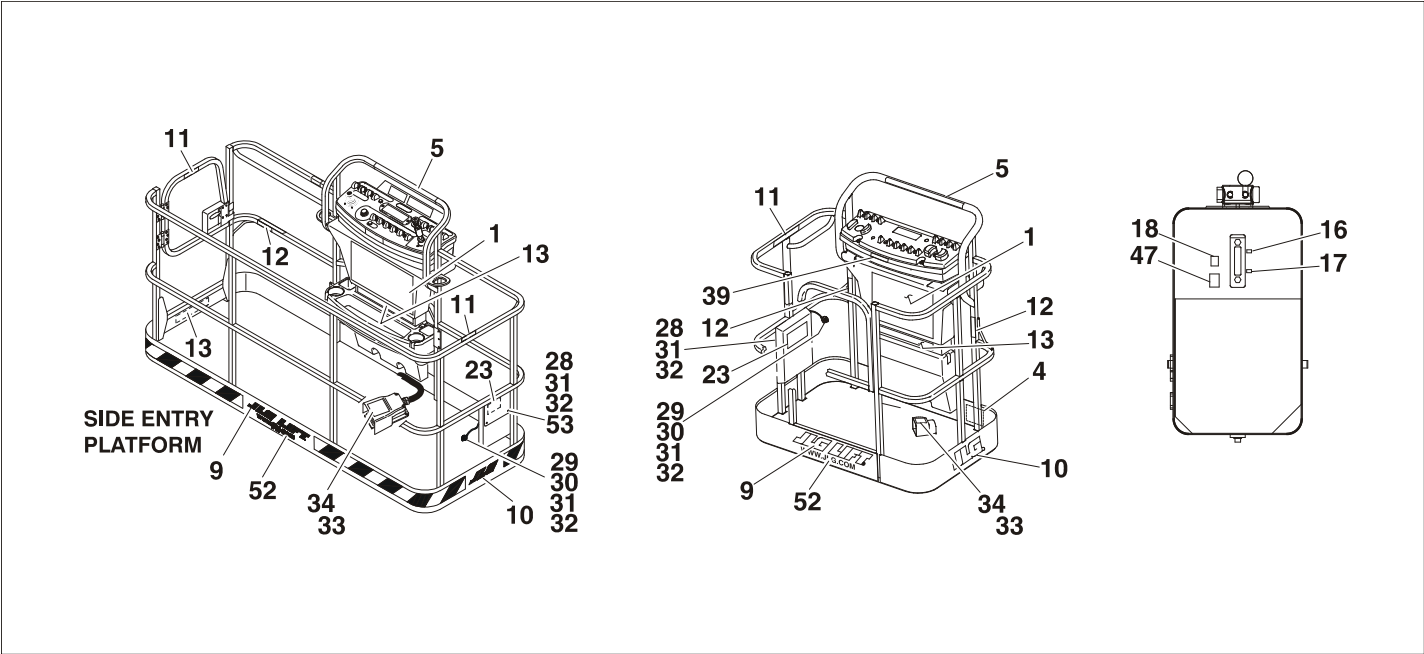

Figure 4-11. Decal Installation - Sheet 4 of 4

SECTION 4 - MACHINE OPERATION

Table 4-1. Decals - 400S with 500 lb (227 or 230 kg) Capacity

Item #	ANSI 0259159-20	CE/Australian 0275066-7	Portuguese/ Spanish 0259185-19	Chinese/ 0259183-23	French 0259181-22	Japanese 0259175-23	Korean 0259177-23	English/ Spanish 0259179-19
1	1703797	1705921	1703928	1703925	1703924	1703926	1703927	1703923
2	1703798	1705822	1703934	1703931	1703930	1703932	1703933	1703929
3	1703805	1705961	1703940	1703937	1703936	1703938	1703939	1703935
4	1703804	1701518	1703952	1703949	1703948	1703950	1703951	1703947
5	1001108492	--	1001108492	1001108492	1001108492	1001108492	1001108492	1001108492
6	1706941	--	1706741	1706941	1706941	1706741	1706941	1706941
7	1704472	1704472	1704472	1704472	1704472	1704472	1704472	1704472
8	--	--	--	--	--	--	--	--
9	--	--	--	--	--	--	--	--
10	--	--	--	--	--	--	--	--
11	1702868	--	1704002	--	1704000	--	--	1704001
12	1704277	1704277	1704277	1704277	1704277	1704277	1704277	1704277
13	1001121800	1705978	1001125330	1001121809	1001121802	1001121807	1001122200	1001121804
14	1001121813	1705978	1001125338	1001121822	1001121815	1001121820	1001122201	1001121817
15	3251813	1705084	3251813	--	3251813	--	--	3251813
16	--	--	--	--	--	--	--	--
17	--	--	--	--	--	--	--	--

SECTION 4 - MACHINE OPERATION

Table 4-1. Decals - 400S with 500 lb (227 or 230 kg) Capacity

Item #	ANSI 0259159-20	CE/Australian 0275066-7	Portuguese/ Spanish 0259185-19	Chinese/ 0259183-23	French 0259181-22	Japanese 0259175-23	Korean 0259177-23	English/ Spanish 0259179-19
18	1701504	1701504	1701504	1701504	1701504	1701504	1701504	1701504
19	--	--	1704008	--	1704006	--	--	1704007
20	1702631	1702631	1702631	1702631	1702631	1702631	1702631	1702631
21	1700584	1700584	1700584	1700584	1700584	1700584	1700584	1700584
22	--	--	--	--	--	--	--	--
23	1701509	1701509	1701509	1701509	1701509	1701509	1701509	1701509
24	1702300	1702300	1702300	1702300	1702300	1702300	1702300	1702300
25	1701500	1701500	1701500	1701500	1701500	1701500	1701500	1701500
26	1701529	1701529	1701529	1701529	1701529	1701529	1701529	1701529
27	--	--	--	--	--	--	--	--
28	--	--	--	--	--	--	--	--
29	--	--	--	--	--	--	--	--
30	--	--	--	--	--	--	--	--
31	--	--	--	--	--	--	--	--
32	--	--	--	--	--	--	--	--
33	--	--	--	--	--	--	--	--
34	--	1705828	1703985	1703982	1703984	1703980	1703981	1703983
35	1706126	1706126	--	1706126	1706126	1706126	1706126	--

SECTION 4 - MACHINE OPERATION

Table 4-1. Decals - 400S with 500 lb (227 or 230 kg) Capacity

Item #	ANSI 0259159-20	CE/Australian 0275066-7	Portuguese/ Spanish 0259185-19	Chinese/ 0259183-23	French 0259181-22	Japanese 0259175-23	Korean 0259177-23	English/ Spanish 0259179-19
36	--	--	--	--	--	--	--	--
37	--	--	--	--	--	--	--	--
38	--	--	--	--	--	--	--	--
39	--	--	--	--	1705514	--	--	--
40	--	--	--	--	--	--	--	--
41	--	--	--	--	--	--	--	--
42	--	--	--	--	--	--	N/A	--
43	--	--	--	--	--	--	N/A	--
44	--	--	--	--	--	--	N/A	--
45	1701499	1701499	1701499	1701499	1701499	1701499	1701499	1701499
46	3252672	1707031	3252685	3252684	3252683	3252680	3252681	3252682
47	1704412	1704412	1704412	1704412	1704412	1704412	1704412	1704412
48	--	--	--	--	--	--	--	--
49	1701691	1701691	1701691	1701691	1701691	1701691	1701691	1701691
50	1704726	1704726	1704726	1704726	1704726	1704726	1704726	1704726
51	--	--	--	--	--	--	--	--
52	--	--	--	--	--	--	--	--

SECTION 4 - MACHINE OPERATION

Table 4-1. Decals - 400S with 500 lb (227 or 230 kg) Capacity

Item #	ANSI 0259159-20	CE/Australian 0275066-7	Portuguese/ Spanish 0259185-19	Chinese/ 0259183-23	French 0259181-22	Japanese 0259175-23	Korean 0259177-23	English/ Spanish 0259179-19
53	--	--	--	--	--	--	--	--
54	1705351	--	1705905	1705430	1705429	1705426	1705427	1705910

SECTION 4 - MACHINE OPERATION

Table 4-2. Decals - 400S with 750 lb (340 kg) Capacity

Item #	ANSI 0259981-17	CE/Australian 0275068-6	Portuguese/ Spanish 0259994-17	Chinese 0259993-20	French 0259992-20	Japanese 0259989-20	Korean 0259990-20	English/ Spanish 0259991-17
1	1703797	1705921	1703928	1703925	1703924	1703926	1703927	1703923
2	1703798	1705822	1703934	1703931	1703930	1703932	1703933	1703929
3	1703805	1705961	1703940	1703937	1703936	1703938	1703939	1703935
4	1703804	1701518	1703952	1703949	1703948	1703950	1703951	1703947
5	1001108492	--	1001108492	1001108492	1001108492	1001108492	1001108492	1001108492
6	1706941	--	1706941	1706741	1706741	1706941	1706941	1706941
7	1704472	1704472	1704472	1704472	1704472	1704472	1704472	1704472
8	--	--	--	--	--	--	--	--
9	--	--	--	--	--	--	--	--
10	--	--	--	--	--	--	--	--
11	1702868	--	1704002	--	1704000	--	--	1704001
12	1704277	1704277	1704277	1704277	1704277	1704277	1704277	1704277
13	1001125322	1706382	1001125329	1001125328	1001125327	1001125323	1001125324	1001125325
14	1001125331	1706382	1001125337	1001125336	1001125335	1001125332	1001125333	1001125334
15	3251813	1705084	3251813	--	3251813	--	--	3251813
16	--	--	--	1701502	--	--	--	1701502
17	--	--	--	1701503	--	--	--	1701503

SECTION 4 - MACHINE OPERATION

Table 4-2. Decals - 400S with 750 lb (340 kg) Capacity

Item #	ANSI 0259981-17	CE/Australian 0275068-6	Portuguese/ Spanish 0259994-17	Chinese 0259993-20	French 0259992-20	Japanese 0259989-20	Korean 0259990-20	English/ Spanish 0259991-17
18	1701504	1701504	1701504	1701504	1701504	1701504	1701504	1701504
19	--	--	1704008	--	1704006	--	--	1704007
20	1702631	1702631	1702631	1702631	1702631	1702631	1702631	1702631
21	1700584	1700584	1700584	1700584	1700584	1700584	1700584	1700584
22	--	--	--	--	--	N/A	--	--
23	1701509	1701509	1701509	1701509	1701509	1701509	1701509	1701509
24	1702300	1702300	1702300	1702300	1702300	1702300	1702300	1702300
25	1701500	1701500	1701500	1701500	1701500	1701500	1701500	1701500
26	1701529	1701529	1701529	1701529	1701529	1701529	1701529	1701529
27	--	--	--	--	--	--	--	--
28	--	--	--	--	--	--	--	--
29	--	--	--	--	--	--	--	--
30	--	--	--	--	--	--	--	--
31	--	--	--	--	--	--	--	--
32	--	--	--	--	--	--	--	--
33	--	--	--	--	--	--	--	--
34	--	1705828	1703985	1703982	1703984	1703980	1703981	1703983
35	1704829	1704829	--	1704829	1704829	1704829	1704829	--

SECTION 4 - MACHINE OPERATION

Table 4-2. Decals - 400S with 750 lb (340 kg) Capacity

Item #	ANSI 0259981-17	CE/Australian 0275068-6	Portuguese/ Spanish 0259994-17	Chinese 0259993-20	French 0259992-20	Japanese 0259989-20	Korean 0259990-20	English/ Spanish 0259991-17
36	--	--	--	--	--	--	--	--
37	--	--	--	--	--	--	--	--
38	--	--	--	--	--	--	--	--
39	--	--	--	--	1705514	--	--	--
40	--	--	--	--	--	--	--	--
41	--	--	--	--	--	--	--	--
42	--	--	--	--	--	--	--	--
43	--	--	--	--	--	--	--	--
44	--	--	--	--	--	--	--	--
45	1701499	1701499	1701499	1701499	1701499	1701499	1701499	1701499
46	3252672	1707031	3252685	3252684	3252683	3252680	3252681	3252682
47	1704412	1704412	1704412	1704412	1704412	1704412	1704412	1704412
48	--	--	--	--	--	--	--	--
49	1701691	1701691	1701691	1701691	1701691	1701691	1701691	1701691
50	1704726	1704726	1704726	1704726	1704726	1704726	1704726	1704726
51	--	--	--	--	--	--	--	--
52	--	--	--	--	--	--	--	--

Table 4-2. Decals - 400S with 750 lb (340 kg) Capacity

Item #	ANSI 0259981-17	CE/Australian 0275068-6	Portuguese/ Spanish 0259994-17	Chinese 0259993-20	French 0259992-20	Japanese 0259989-20	Korean 0259990-20	English/ Spanish 0259991-17
53	--	--	--	--	--	--	--	--
54	1705351	--	1705905	1705430	1705429	1705426	1705427	1705910

SECTION 4 - MACHINE OPERATION

Table 4-3. Decals - 460SJ

Item #	ANSI 0259160-16	CE/Australian 1001114405-1	Portuguese/ Spanish 0259186-19	Chinese 0259184-22	French 0259182-21	Japanese 0259176-21	Korean 0259178-20	English/ Spanish 0259180-18
1	1703797	1705921	1703928	1703925	1703924	1703926	1703927	1703923
2	1703798	1705822	1703934	1703931	1703930	1703932	1703933	1703929
3	1703805	1705961	1703940	1703937	1703936	1703938	1703939	1703935
4	1703804	1701518	1703952	1703949	1703948	1703950	1703951	1703947
5	1706708	--	1706941	1001108492	1001108492	1001108492	1001108492	1001108492
6	1706941	--	1706709	1706941	1706941	1706941	1706941	1706941
7	1704473	1704473	1704473	1704473	1704473	1704473	1704473	1704473
8	--	--	--	--	--	--	--	--
9	--	--	--	--	--	--	--	--
10	--	--	--	--	--	--	--	--
11	1702868	--	1704002	--	1704000	--	--	1704001
12	1704277	1704277	1704277	1704277	1704277	1704277	1704277	1704277
13	1001121801	1705978	1001121920	1001121812	1001121803	1001121808	1001121918	1001121801
14	1001121814	1705978	1001121923	1001121825	1001121816	1001121821	1001121921	1001121814
15	3251813	1705084	3251813	--	3251813	--	--	3251813
16	--	--	--	--	--	--	--	--
17	--	--	--	--	--	--	--	--

SECTION 4 - MACHINE OPERATION**Table 4-3. Decals - 460SJ**

Item #	ANSI 0259160-16	CE/Australian 1001114405-1	Portuguese/ Spanish 0259186-19	Chinese 0259184-22	French 0259182-21	Japanese 0259176-21	Korean 0259178-20	English/ Spanish 0259180-18
18	1701504	1701504	1701504	1701504	1701504	1701504	1701504	1701504
19	--	--	1704008	--	1704006	--	--	1704007
20	1702631	1702631	1702631	1702631	1702631	1702631	1702631	1702631
21	1700584	1700584	1700584	1700584	1700584	1700584	1700584	1700584
22	--	--	--	--	--	--	--	--
23	1701509	1701509	1701509	1701509	1701509	1701509	1701509	1701509
24	1702300	1702300	1702300	1702300	1702300	1702300	1702300	1702300
25	1701500	1701500	1701500	1701500	1701500	1701500	1701500	1701500
26	1701529	1701529	1701529	1701529	1701529	1701529	1701529	1701529
27	--	--	--	--	--	--	--	--
28	--	--	--	--	--	--	--	--
29	--	--	--	--	--	--	--	--
30	--	--	--	--	--	--	--	--
31	--	--	--	--	--	--	--	--
32	--	--	--	--	--	--	--	--
33	--	--	--	--	--	--	--	--
34	--	1705828	1703985	1703982	1703984	1703980	1703981	1703983
35	1704828	1704828	--	1704828	1704828	1704828	1704828	--

SECTION 4 - MACHINE OPERATION

Table 4-3. Decals - 460SJ

Item #	ANSI 0259160-16	CE/Australian 1001114405-1	Portuguese/ Spanish 0259186-19	Chinese 0259184-22	French 0259182-21	Japanese 0259176-21	Korean 0259178-20	English/ Spanish 0259180-18
36	--	--	--	--	--	--	--	--
37	--	--	--	--	--	--	--	--
38	--	--	--	--	--	--	--	--
39	--	--	--	--	1705514	--	--	--
40	--	--	--	--	--	--	--	--
41	--	--	--	--	--	--	--	--
42	--	--	--	--	--	--	--	--
43	--	--	--	--	--	--	--	--
44	--	--	--	--	--	--	--	--
45	1701499	1701499	1701499	1701499	1701499	1701499	1701499	1701499
46	3252672	1707031	3252685	3252684	3252683	3252680	3252681	3252682
47	1704412	1704412	1704412	1704412	1704412	1704412	1704412	1704412
48	--	--	--	--	--	--	--	--
49	1701691	1701691	1701691	1701691	1701691	1701691	1701691	1701691
50	1704726	1704726	1704726	1704726	1704726	1704726	1704726	1704726
51	--	--	--	--	--	--	--	--
52	--	--	--	--	--	--	--	--
53	--	--	--	--	--	--	--	--

Table 4-3. Decals - 460SJ

Item #	ANSI 0259160-16	CE/Australian 1001114405-1	Portuguese/ Spanish 0259186-19	Chinese 0259184-22	French 0259182-21	Japanese 0259176-21	Korean 0259178-20	English/ Spanish 0259180-18
54	1705351	--	1705905	1705430	1705429	1705426	1702427	1705910
55	--	1001112551	--	--	--	--	--	--

SECTION 5. EMERGENCY PROCEDURES

5.1 GENERAL

This section explains the steps to be taken in case of an emergency situation while operating.

5.2 INCIDENT NOTIFICATION

JLG Industries, Inc. must be notified immediately of any incident involving a JLG product. Even if no injury or property damage is evident, the factory should be contacted by telephone and provided with all necessary details.

In USA:

JLG Phone: 877-JLG-SAFE (554-7233)
(8am till 4:45pm EST)

Outside USA:

240-420-2661

E-mail:

ProductSafety@JLG.com

Failure to notify the manufacturer of an incident involving a JLG Industries product within 48 hours of such an occurrence may void any warranty consideration on that particular machine.

NOTICE

FOLLOWING ANY ACCIDENT, THOROUGHLY INSPECT THE MACHINE AND TEST ALL FUNCTIONS FIRST FROM THE GROUND CONTROLS, THEN FROM THE PLATFORM CONTROLS. DO NOT LIFT ABOVE 10 FT. (3 M) UNTIL YOU ARE SURE THAT ALL DAMAGE HAS BEEN REPAIRED, IF REQUIRED, AND THAT ALL CONTROLS ARE OPERATING CORRECTLY.

5.3 EMERGENCY OPERATION

Operator Unable to Control Machine

IF THE PLATFORM OPERATOR IS PINNED, TRAPPED OR UNABLE TO OPERATE OR CONTROL MACHINE:

1. Other personnel should operate the machine from ground controls only as required.
2. Other qualified personnel on the platform may use the platform controls. DO NOT CONTINUE OPERATION IF CONTROLS DO NOT FUNCTION PROPERLY.
3. Cranes, forklift trucks or other equipment can be used to remove platform occupants and stabilize motion of the machine.

Platform or Boom Caught Overhead

If the platform or boom becomes jammed or snagged in overhead structures or equipment, rescue platform occupants prior to freeing the machine.

5.4 EMERGENCY TOWING PROCEDURES

Towing this machine is prohibited, unless properly equipped. However, provisions for moving the machine have been incorporated. For specific procedures, refer to Section 4.

SECTION 6. GENERAL SPECIFICATIONS & OPERATOR MAINTENANCE

6.1 INTRODUCTION

This section of the manual provides additional necessary information to the operator for proper operation and maintenance of this machine.

The maintenance portion of this section is intended as information to assist the machine operator to perform daily maintenance tasks only, and does not replace the more thorough Preventive Maintenance and Inspection Schedule included in the Service and Maintenance Manual.

Other Publications Available:

Service and Maintenance Manual (ANSI, CSA)	3120788
Service and Maintenance Manual (CE, AUS).....	3120895
Illustrated Parts Manual (ANSI, CSA) Prior to S/N 96000.....	3120789
Illustrated Parts Manual (CE, AUS) Prior to S/N 96000.....	3120896
Illustrated Parts Manual (Global) S/N 96000 to Present.....	3121236

6.2 OPERATING SPECIFICATIONS

Table 6-1. Operating Specifications - 400S - Prior to S/N 0300142870

Maximum Work Load (Capacity): Unrestricted: Restricted: Optional:	standard 500 lbs. (230 kg.) 1000 lbs. (450 kg) 750 lbs. (340 kg)
Maximum Travel Grade, Stowed Position (Gradeability) see Figure 4-3.	2 W/D-30% 4 W/D-45%
Maximum Travel Grade, Stowed Position (Side Slope) see Figure 4-3.	5°
Maximum Vertical Platform Height:	40 ft. (12 m)
Maximum Horizontal Platform Reach:	34 ft. (10 m.)
Turning Radius (Outside)	16 ft. (5 m.)
Turning Radius (Inside)	6 ft.-8 in. (2 m.)
Overall Width	6ft.- 6in. (1.98 m)
Tail swing	Zero
Stowed Height	7ft. 4in. (2.24 m)

SECTION 6 - GENERAL SPECIFICATIONS & OPERATOR MAINTENANCE

Table 6-1. Operating Specifications - 400S - Prior to S/N 0300142870

Stowed Length	20ft. 2in. (6.15 m)
Wheelbase	7ft. 10in. (2,3 m)
Ground Clearance	12in. (30 cm)
Max. Tire Load (400S-500 lbs. Cap.) Max. Tire Load (400S-750 lbs. Cap.)	6200 lbs. (2812 kg) 8350 lbs. (3788 kg)
Ground Bearing Pressure 12x16.5 FF Tires 14x17.5 pneumatic tires	58 psi (4.07 kg/cm ²) 45 psi (3.16 kg/cm ²)
Travel Speed, boom stowed. (2WD/4WD)	4.5 m.p.h. (7.24 kmh) (27-32 sec/ 200ft.)
Travel Speed, boom elevated. (2WD/4WD)	0.75 m.p.h. (1.20 kmh) (46-115 sec/ 50 ft.)
Gross Machine Weight Std. 2wd Machine (Platform Empty, Pneumatic Tires) 500 lb. (230 kg) Capacity 750 lb. (340 kg) Capacity	12,525 lbs. (5681kg) 13,525 lbs. (6135 kg)
Maximum System Voltage	12 VDC
Max. Hydraulic System Operating Pressure	4060 psi (280 bar)
Manual Force	400 N maximum
Maximum Wind Speed	28 mph (12.5 m/s)

Table 6-2. Operating Specifications - 400S - S/N 0300142870 to Present

Maximum Work Load (Capacity) - ANSI Unrestricted: Restricted: Optional:	standard 500 lbs. (227 kg.) 1000 lbs. (454 kg) 750 lbs. (340 kg)
Maximum Work Load (Capacity) - CE & Australia Unrestricted: Restricted: Optional:	standard 500 lbs. (230 kg.) 1000 lbs. (450 kg) 750 lbs. (340 kg)
Maximum Travel Grade, Stowed Position (Gradeability) see Figure 4-3.	2 W/D-30% 4 W/D-45%
Maximum Travel Grade, Stowed Position (Side Slope) see Figure 4-3.	5°
Maximum Vertical Platform Height:	40 ft. (12 m)
Maximum Horizontal Platform Reach:	34 ft. (10 m.)
Turning Radius (Outside)	16 ft. (5 m.)
Turning Radius (Inside)	6 ft. -8 in. (2 m.)
Overall Width	6ft. - 6in. (1.98 m)
Tail swing	Zero
Stowed Height	7ft. 4in. (2.24 m)

SECTION 6 - GENERAL SPECIFICATIONS & OPERATOR MAINTENANCE

Table 6-2. Operating Specifications - 400S - S/N 0300142870 to Present

Stowed Length	20ft. 2in. (6.15 m)
Wheelbase	7ft. 10in. (2,3 m)
Ground Clearance	12in. (30 cm)
Max. Tire Load (400S-500 lbs. Cap.) Max. Tire Load (400S-750 lbs. Cap.)	6200 lbs. (2812 kg) 8350 lbs. (3788 kg)
Ground Bearing Pressure 12x16.5 FF Tires 14x17.5 pneumatic tires	58 psi (4.07 kg/cm ²) 45 psi (3.16 kg/cm ²)
Travel Speed, boom stowed. (2WD/4WD)	4.5 m.p.h. (7.24 kmh) (27-32 sec/200ft.)
Travel Speed, boom elevated. (2WD/4WD)	0.75 m.p.h. (1.20 kmh) (46-115 sec/50 ft.)
Gross Machine Weight Std. 2wd Machine (Platform Empty, Pneumatic Tires) 500 lb. (227 or 230 kg) Capacity 750 lb. (340 kg) Capacity	12,525 lbs. (5681kg) 13,525 lbs. (6135 kg)
Maximum System Voltage	12 VDC
Max. Hydraulic System Operating Pressure	4060 psi (280 bar)
Manual Force	400 N maximum
Maximum Wind Speed	28 mph (12.5 m/s)

Table 6-3. Operating Specifications - 460SJ - Prior to S/N 0300142870

Maximum Work Load (Capacity): Unrestricted:	500 lbs. (230 kg.)
Maximum Travel Grade, Stowed Position (Gradeability) see Figure 4-3.	2 W/D - 30% 4 W/D - 45%
Maximum Travel Grade, Stowed Position (Side Slope) see Figure 4-3.	5°
Maximum Vertical Platform Height:	46 ft. (14 m.)
Maximum Horizontal Platform Reach:	40 ft. (12 m.)
Turning Radius (Outside)	16ft. (5 m.)
Turning Radius (Inside)	6 ft.-8 in. (2 m.)
Overall Width	6ft.- 6in. (1.98 m)
Tail swing	zero
Stowed Height	7ft. 4in. (2.24 m)
Stowed Length	20ft. 2in. (6.15 m)
Wheelbase	7ft. 10in. (2,3 m)
Ground Clearance	12in. (30 cm)
Max. Tire Load	7200 lbs. (3266 kg)
Ground Bearing Pressure	63 psi (4.4 kg/cm ²)

SECTION 6 - GENERAL SPECIFICATIONS & OPERATOR MAINTENANCE

Table 6-3. Operating Specifications - 460SJ - Prior to S/N 0300142870

Travel Speed, boom stowed. (2WD/4WD)	4.5 m.p.h. (7.24 kmh) (27-32 sec/ 200ft.)
Travel Speed, boom elevated. (2WD/4WD)	0.75 m.p.h. (1.20 kmh) (46-115 sec/ 50 ft.)
Gross Machine Weight Std. 2wd Machine (Platform Empty, Pneumatic Tires)	7192 kg (15,855 lb.)
Maximum System Voltage	12 VDC
Max. Hydraulic System Operating Pressure	4060 psi (280 bar)
Maximum Manual Force	400 N
Maximum Wind Speed	28 mph (12.5 m/s)

Table 6-4. Operating Specifications - 460SJ - S/N 0300142870 to Present

Maximum Work Load (Capacity) - ANSI Unrestricted:	500 lbs. (227 kg.)
Maximum Work Load (Capacity) - CE & Australia Unrestricted:	500 lbs. (230 kg.)
Maximum Travel Grade, Stowed Position (Gradeability) see Figure 4-3.	2 W/D - 30% 4 W/D - 45%
Maximum Travel Grade, Stowed Position (Side Slope) see Figure 4-3.	5°
Maximum Vertical Platform Height:	46 ft. (14 m.)
Maximum Horizontal Platform Reach:	40 ft. (12 m.)
Turning Radius (Outside)	16 ft. (5 m.)
Turning Radius (Inside)	6 ft.-8 in. (2 m.)
Overall Width	6ft. - 6in. (1.98 m)
Tail swing	zero
Stowed Height	7ft. 4in. (2.24 m)
Stowed Length	20ft. 2in. (6.15 m)
Wheelbase	7ft. 10in. (2,3 m)
Ground Clearance	12in. (30 cm)

SECTION 6 - GENERAL SPECIFICATIONS & OPERATOR MAINTENANCE

Table 6-4. Operating Specifications - 460SJ - S/N 0300142870 to Present

Max. Tire Load	7200 lbs. (3266 kg)
Ground Bearing Pressure	63 psi (4.4 kg/cm ²)
Travel Speed, boom stowed. (2WD/4WD)	4.5 m.p.h. (7.24 kmh) (27-32 sec/ 200ft.)
Travel Speed, boom elevated. (2WD/4WD)	0.75 m.p.h. (1.20 kmh) (46-115 sec/ 50 ft.)
Gross Machine Weight Std. 2wd Machine (Platform Empty, Pneumatic Tires)	7192 kg (15,855 lb.)
Maximum System Voltage	12 VDC
Max. Hydraulic System Operating Pressure	4060 psi (280 bar)
Maximum Manual Force	400 N
Maximum Wind Speed	28 mph (12.5 m/s)

Capacities

Table 6-5. Capacities

Fuel Tank	26 gallons (98.4 liters)
Hydraulic Tank	40.0 gallons (152 liters)
Hydraulic System (Including Tank)	52 gallons (196.8 liters)
Drive Hub	17 ounces (0.5 liters)
Engine Oil Capacity	
Ford	4.5 Quarts (4.25 L) w/Filter
Deutz	6.3 qts. (6 L) w/Filter
Caterpillar	3.8 quarts (3.6 L) crankcase only
GM	4.5 qts. (4.25 L) w/Filter

SECTION 6 - GENERAL SPECIFICATIONS & OPERATOR MAINTENANCE

Engine

NOTE: RPM Tolerances are ± 100 .

Table 6-6. Ford LRG-425 (Gas or Dual Fuel)

Type	4 cylinder, 4 stroke, spark ignition
Fuel	Gasoline or Gasoline/LP Gas
Bore	3 in. (96 mm)
Stroke	3.4 in. (86.4 mm)
Displacement	153 cu. in. (2.5 L)
Firing Order	1-3-4-2
BHP at Max. RPM	82
Oil Capacity	4.5 quarts (4.26 L)
Low RPM	1000
Mid RPM	1800
High RPM	3000
Fuel Consumption: Gasoline Intermittent	6 gal. hr.
Continuous	5 gal. hr.
Fuel Consumption: LPG Intermittent	26 lbs. hr.
Continuous	23 lbs. hr.

Table 6-6. Ford LRG-425 (Gas or Dual Fuel)

Spark Plug	AWSF-52-C
Spark Plug Gap	0.044 in. (1.117 mm)

Table 6-7. Deutz F3M1011F/F3M2011F/D2011L03

Fuel	Diesel
No. of Cylinders	3
Bore	3.7 in. (94 mm)
Stroke	4.4 in. (112 mm)
Displacement	142 cu. in. (2331 cm ³)
BHP at Max. RPM	49
Oil Capacity crankcase	6.3 quarts (6 L)
cooler	4.75 quarts (4.5 L)
total capacity	11 quarts (10.5 L)
Low RPM	1200
Mid RPM	1800
High RPM	2800

SECTION 6 - GENERAL SPECIFICATIONS & OPERATOR MAINTENANCE

Table 6-8. Isuzu 4LE1

Fuel	Diesel
No. of Cylinders	4
BHP at Max. RPM	45
Low RPM	1000
Mid RPM	1500
High RPM	2800

Table 6-9. Caterpillar 3024/C2.2

Fuel	Diesel
No. of Cylinders	4
BHP	46.5 hp (34 kW)
Bore	3.307 in. (84 mm)
Stroke	3.9370 in. (112 mm)
Displacement	134.3 cu. in. (2.2L)
Oil Capacity	3.8 quarts (3.6 L) crankcase only
Compression Ratio	19:1
Firing Order	1-3-4-2
Max. RPM	2800

Table 6-10. GM 3.0L

Fuel	Gasoline or Gasoline/LP Gas
No. of Cylinders	4
BHP	
Gasoline	83 hp @ 3000 rpm
LP	75 hp @ 3000 rpm
Bore	4.0 in. (101.6 mm)
Stroke	3.6 in. (91.44 mm)
Displacement	181 cu.in. (3.0 L, 2966 cc)
Oil Capacity w/filter	4.5 qts. (4.25 L)
Minimum Oil Pressure	
at idle	6 psi (0.4 Bar) @ 1000 rpm
Hot	18 psi (1.2 Bar) @ 2000 rpm
Compression Ratio	9.2:1
Firing Order	1-3-4-2
Max. RPM	2800

SECTION 6 - GENERAL SPECIFICATIONS & OPERATOR MAINTENANCE

Table 6-11. Perkins 404D-22

Fuel	Diesel
No. of Cylinders	4
BHP	50 HP (37.3 kW)
Bore	3.3 in. (84 mm)
Stroke	3.9 in. (100 mm)
Firing Order	1-3-4-2
Displacement	135 cu.in. (2.2 L)
Oil Capacity w/filter	10 qt. (9.4 L)
Compression Ratio	23.3:1

Tires

Table 6-12. Tires

Size	Type	Pressure	Weight
12x16.5	Pneumatic	90 psi (6.2 Bar)	128 lbs. (58 kg)
12x16.5	Foam-filled	N/A	328 lbs. (149kg)
14x17.5	Pneumatic	90 psi (6 Bar)	128 lbs. (58 kg)
14x17.5	Foam-filled	N/A	440 lbs. (200kg)
33/16LLx16.1- Sand	Pneumatic	90 psi (2.75 bar)	119.5 lbs. (54 kg)
33/16LLx16.1- Sand	Foam Filled	N/A	426 lbs. (193 kg)
33x6x11	Solid	N/A	280 lbs. (127 kg)
Semitrack Tires			
24x12x12	Pneumatic	20 psi (1.4 bar)	20.7 lbs. (9.38 kg)

Hydraulic Oil

Table 6-13. Hydraulic Oil

Hydraulic System Operating Temperature Range	S.A.E. Viscosity Grade
+0° to +180° F (-18° to +83° C)	10W
+0° to +210° F (-18° to +99° C)	10W-20, 10W30
+50° to +210° F (+10° to +99° C)	20W-20

NOTE: Hydraulic oils must have anti-wear qualities at least to API Service Classification GL-3, and sufficient chemical stability for mobile hydraulic system service. JLG Ind. recommends Mobilfluid 424 hydraulic oil, which has an SAE viscosity index of 152.

NOTE: When temperatures remain consistently below 20° F (-7° C), JLG Industries recommends the use of Mobil DTE-13.

NOTE: Machines may be equipped with Mobil EAL224H biodegradable and non-toxic hydraulic oil. This is Vegetable oil based and possesses the same antiwear and rust protection characteristics as mineral oils, but will not adversely affect the ground water or the environment when spilled or leaked in small amounts. Mobil EAL224H has a viscosity of 34 cSt at 40° C. and viscosity index of 213. The operating temperature range of this oil is -18° C to +83° C.

Aside from JLG recommendations, it is not advisable to mix oils of different brands or types, as they may not contain the same required additives or be of comparable viscosities. If use of hydraulic oil other than Mobilfluid 424 is desired, contact JLG Industries for proper recommendations.

Table 6-14. Mobilfluid 424 Specs

SAE Grade	10W30
Gravity, API	29.0
Density, Lb/Gal. 60°F	7.35
Pour Point, Max	-46°F (-43°C)
Flash Point, Min.	442°F (228°C)
Viscosity	
Brookfield, cP at -18°C	2700
at 40° C	55 cSt
at 100° C	9.3 cSt
Viscosity Index	152

SECTION 6 - GENERAL SPECIFICATIONS & OPERATOR MAINTENANCE

Table 6-15. UCon Hydrolube HP-5046

Type	Synthetic Biodegradable
Specific Gravity	1.082
Pour Point, Max	-58°F (-50°C)
pH	9.1
Viscosity	
at 0° C (32° F)	340 cSt (1600SUS)
at 40° C (104° F)	46 cSt (215SUS)
at 65° C (150° F)	22 cSt (106SUS)
Viscosity Index	170

Table 6-16. Mobil EAL 224H Specs

Type	Biodegradable Vegetable Oil
ISO Viscosity Grade	32/46
Specific Gravity	.922
Pour Point, Max	-25°F (-32°C)
Flash Point, Min.	428°F (220°C)
Operating Temp.	0 to 180°F (-17 to 162°C)
Weight	7.64 lb. per gal. (0.9 kg per liter)
Viscosity	
at 40° C	37 cSt
at 100° C	8.4 cSt
Viscosity Index	213
NOTE: Must be stored above 32°F (0°C)	

SECTION 6 - GENERAL SPECIFICATIONS & OPERATOR MAINTENANCE

Table 6-17. Mobil EAL EnviroSyn H Specs

Type	Synthetic Biodegradable
ISO Viscosity Grade	32
Specific Gravity	.950
Pour Point, Max	-59°F (-51°C)
Flash Point, Min.	514°F (268°C)
Viscosity	
at 40° C	33.1 cSt
at 100° C	6.36 cSt
Viscosity Index	147

Table 6-18. Exxon Univis HVI 26 Specs

Specific Gravity	32.1
Pour Point	-76°F (-60°C)
Flash Point	217°F (103°C)
Viscosity	
at 40° C	25.8 cSt
at 100° C	9.3 cSt
Viscosity Index	376
NOTE: Mobil/Exxon recommends that this oil be checked on a yearly basis for viscosity.	

Critical Stability Weights**Table 6-19. Critical Stability Weights**

Component	LB.	KG
Ford Engine	339	154
Deutz Engine	441	200
8 ft Platform (x 30")	205	93
6 ft. Platform (x 30")	160	73
5 ft. Platform (x 30")	145	66
4ft. Platform (x 30")	130	59
8 ft. Platform (x 36")	230	105
Bolt-on T/T Cwt. (SJ)	487	221
12 x16.5 pneu. Tire & Wheel	128	58
12 x16.5 F/F Tire & Wheel	440	200
12 x 21.5 (NHS) pneu. Tire & Wheel	55	97
12 x 21.5 (NHS) F/F Tire & Wheel	224	102
14 x16.1 Sand pneu. Tire & Wheel	91.5	42
14 x16.1 Sand F/F Tire & Wheel	440	200

Serial Number Location

A serial number plate is affixed to the left rear side of the frame. If the serial number plate is damaged or missing, the machine serial number is stamped on the left side of the frame.

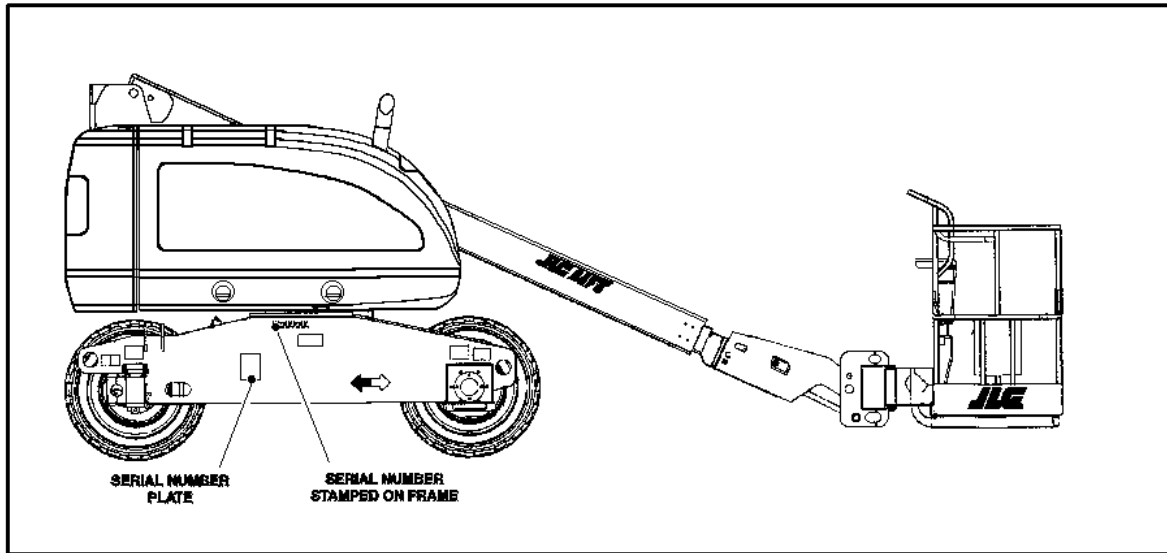

Figure 6-1. Serial Number Location

SECTION 6 - GENERAL SPECIFICATIONS & OPERATOR MAINTENANCE

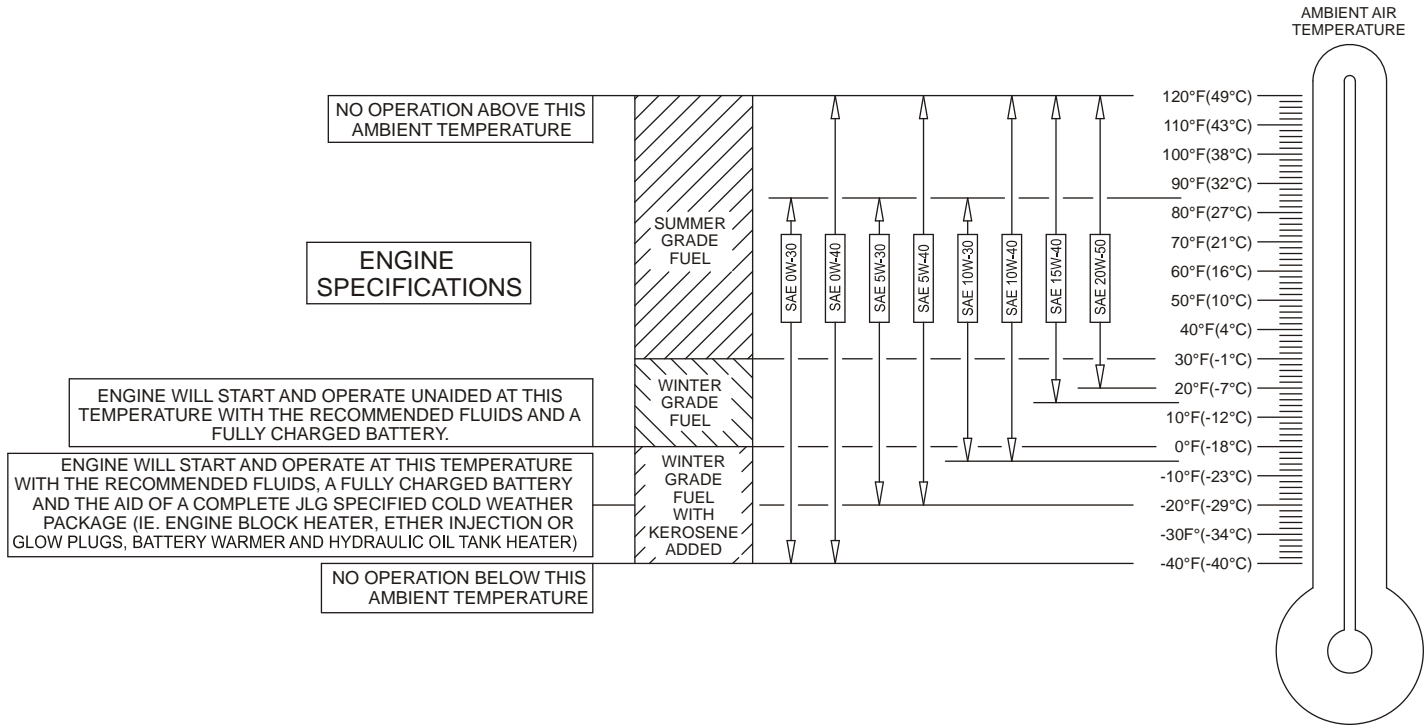

Figure 6-2. Engine Operating Temperature Specifications - Deutz - Sheet 1 of 2

SECTION 6 - GENERAL SPECIFICATIONS & OPERATOR MAINTENANCE

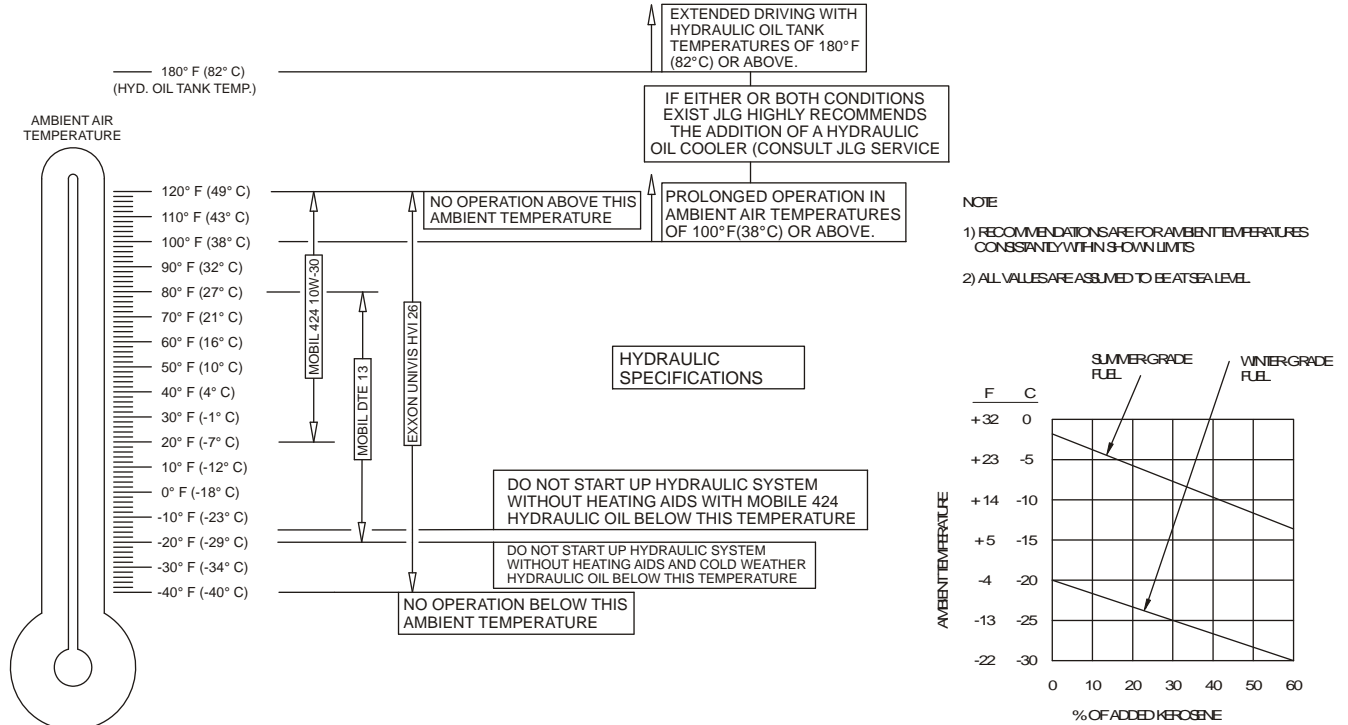

Figure 6-3. Engine Operating Temperature Specifications - Deutz - Sheet 2 of 2

SECTION 6 - GENERAL SPECIFICATIONS & OPERATOR MAINTENANCE

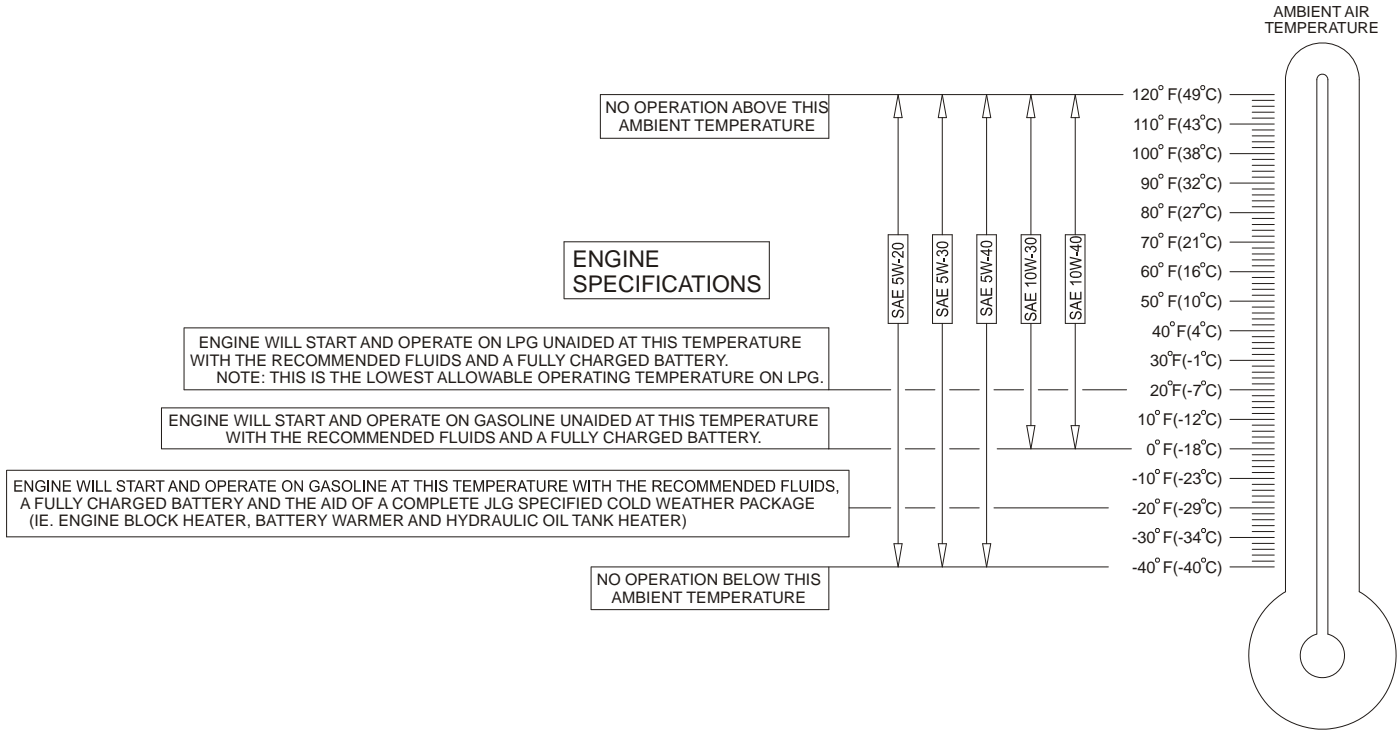
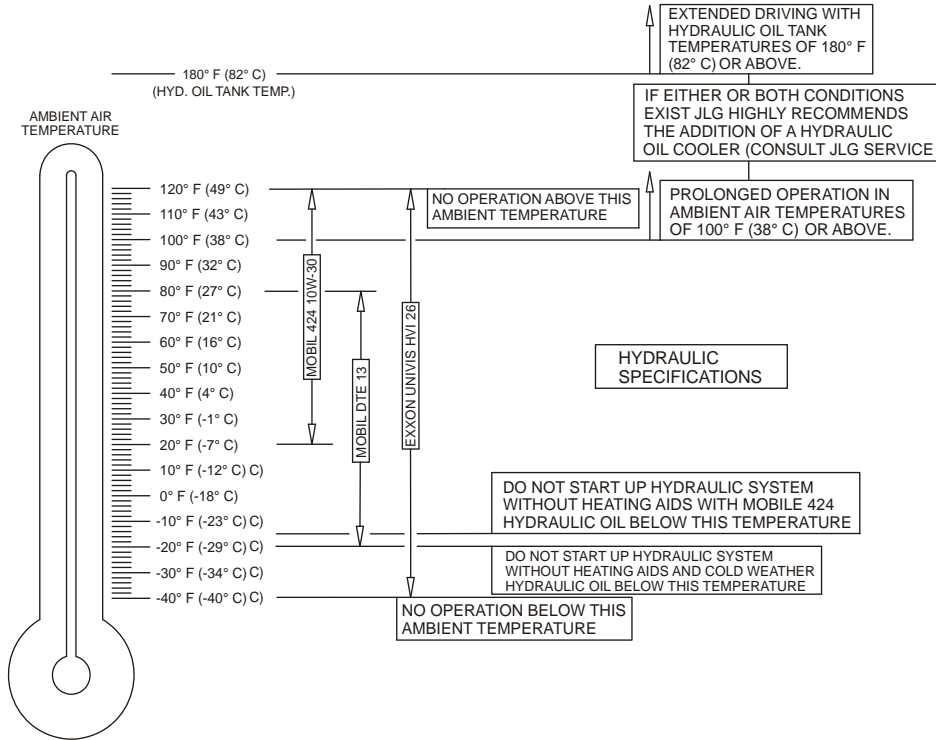

Figure 6-4. Engine Operating Temperature Specifications - Ford - Sheet 1 of 2

SECTION 6 - GENERAL SPECIFICATIONS & OPERATOR MAINTENANCE



NOTE:

- 1) RECOMMENDATIONS ARE FOR AMBIENT TEMPERATURES CONSISTANTLY WITHIN SHOWN LIMITS
- 2) ALL VALUES ARE ASSUMED TO BE AT SEA LEVEL.

Figure 6-5. Engine Operating Temperature Specifications - Ford - Sheet 2 of 2

4150548-E

SECTION 6 - GENERAL SPECIFICATIONS & OPERATOR MAINTENANCE

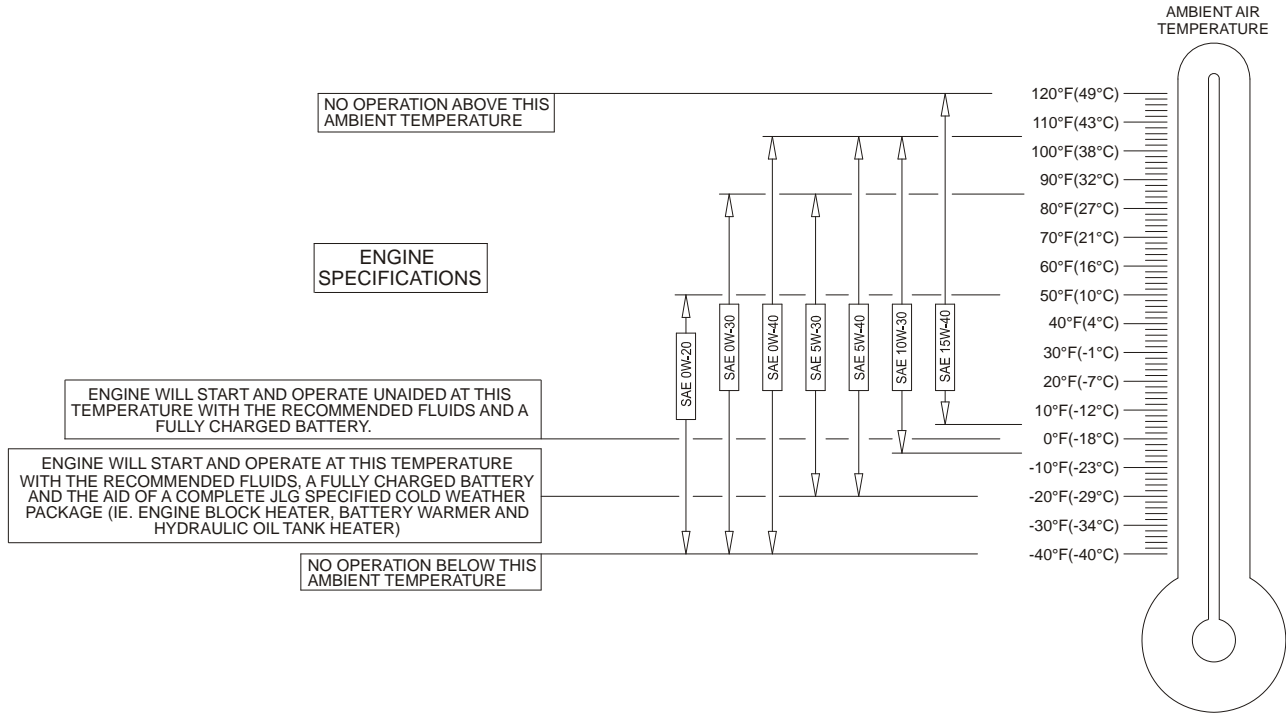
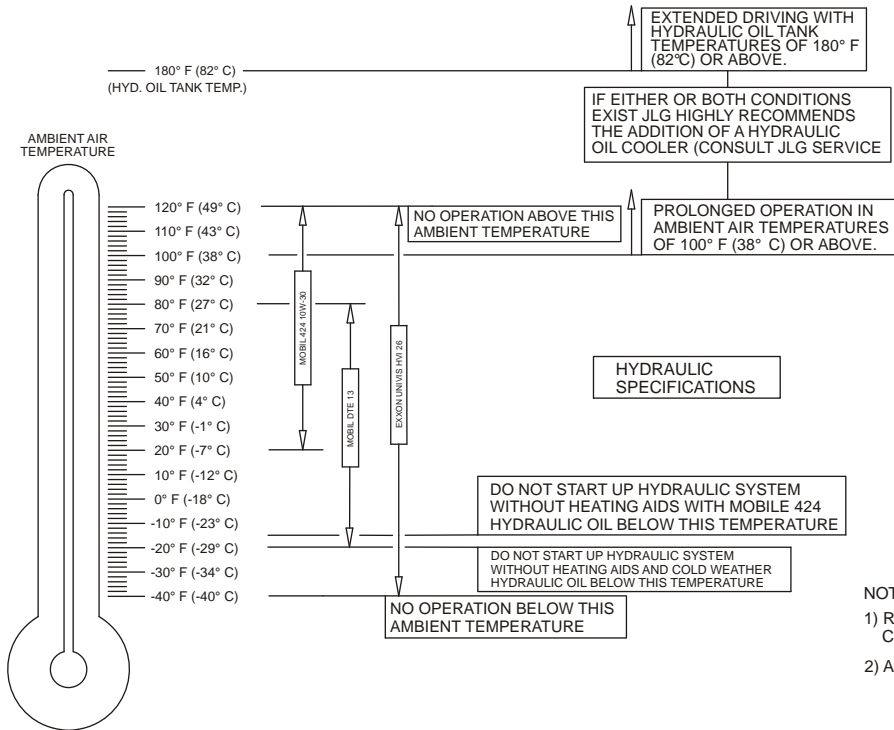

Figure 6-6. Engine Operating Temperature Specifications - Caterpillar - Sheet 1 of 2

SECTION 6 - GENERAL SPECIFICATIONS & OPERATOR MAINTENANCE



NOTE:

- 1) RECOMMENDATIONS ARE FOR AMBIENT TEMPERATURES CONSISTENTLY WITHIN SHOWN LIMITS
- 2) ALL VALUES ARE ASSUMED TO BE AT SEA LEVEL.

4150548-E

Figure 6-7. Engine Operating Temperature Specifications - Caterpillar - Sheet 2 of 2

SECTION 6 - GENERAL SPECIFICATIONS & OPERATOR MAINTENANCE

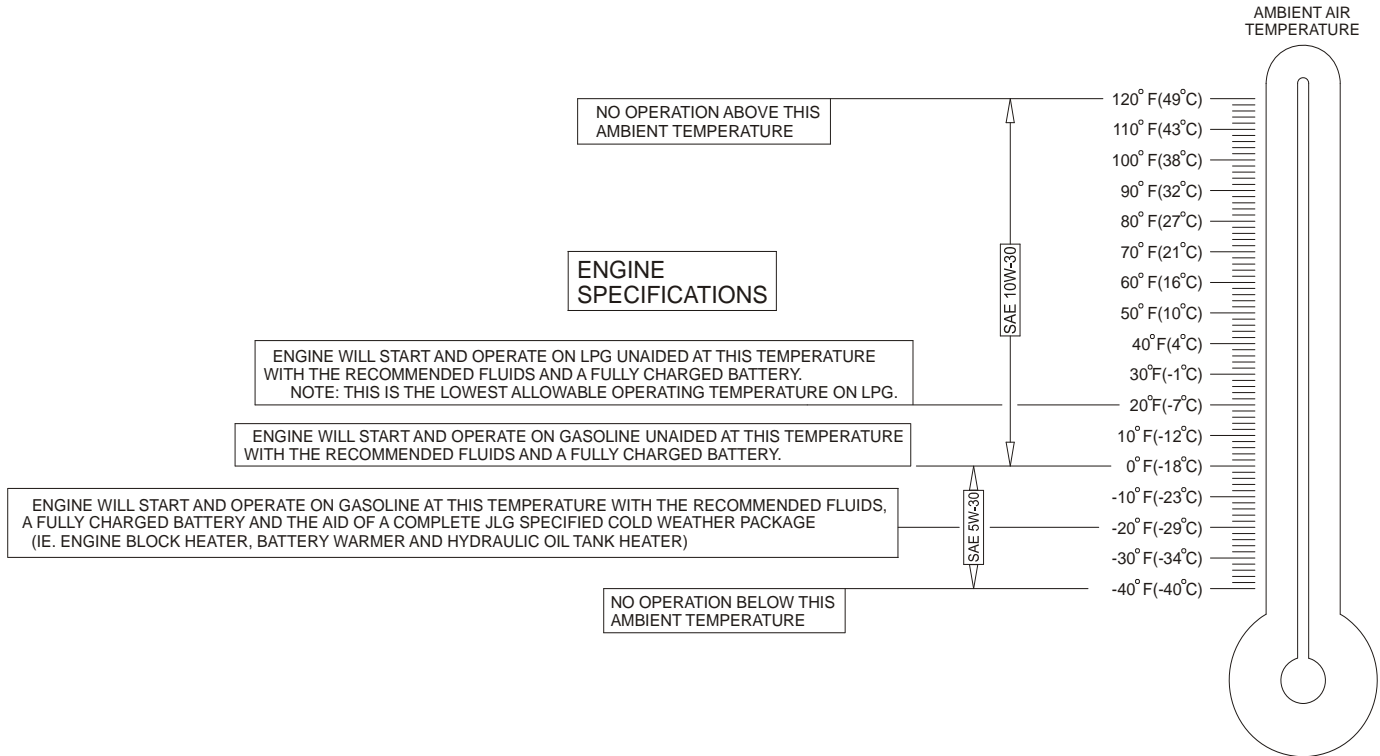

Figure 6-8. Engine Operating Temperature Specifications - GM - Sheet 1 of 2

SECTION 6 - GENERAL SPECIFICATIONS & OPERATOR MAINTENANCE

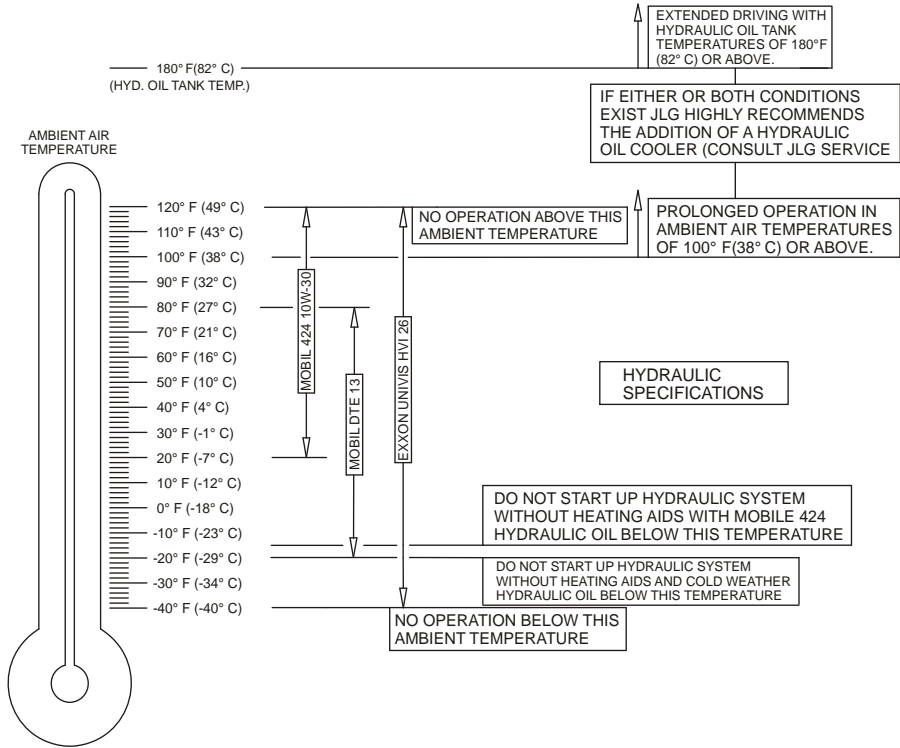

Figure 6-9. Engine Operating Temperature Specifications - GM - Sheet 2 of 2

4150548-E

SECTION 6 - GENERAL SPECIFICATIONS & OPERATOR MAINTENANCE

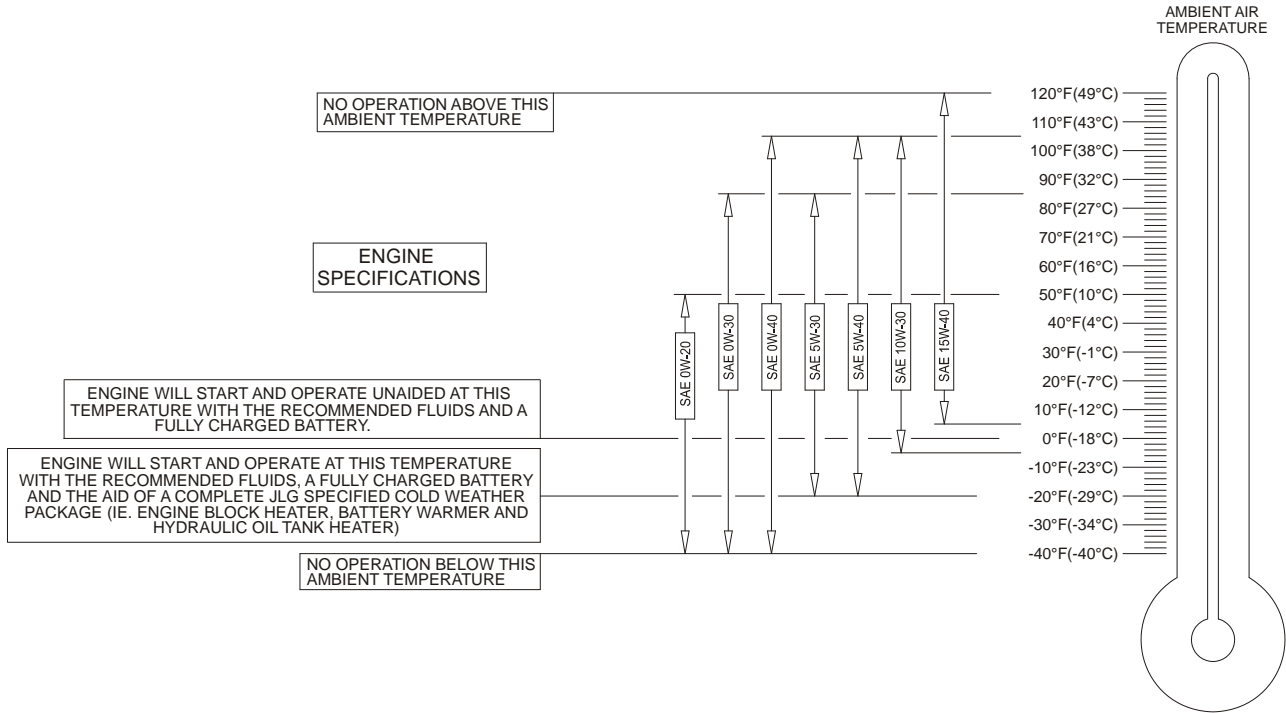
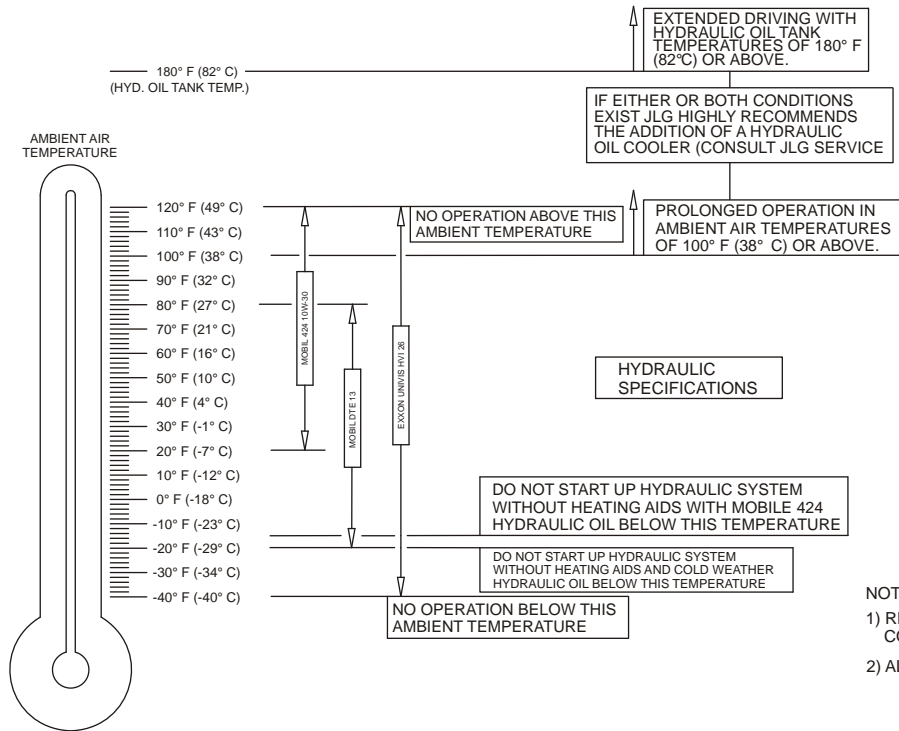

Figure 6-10. Engine Operating Temperature Specifications - Perkins - Sheet 1 of 2

SECTION 6 - GENERAL SPECIFICATIONS & OPERATOR MAINTENANCE



- NOTE:
- 1) RECOMMENDATIONS ARE FOR AMBIENT TEMPERATURES CONSISTENTLY WITHIN SHOWN LIMITS
 - 2) ALL VALUES ARE ASSUMED TO BE AT SEA LEVEL.

Figure 6-11. Engine Operating Temperature Specifications - Perkins - Sheet 2 of 2

4150548-E

SECTION 6 - GENERAL SPECIFICATIONS & OPERATOR MAINTENANCE

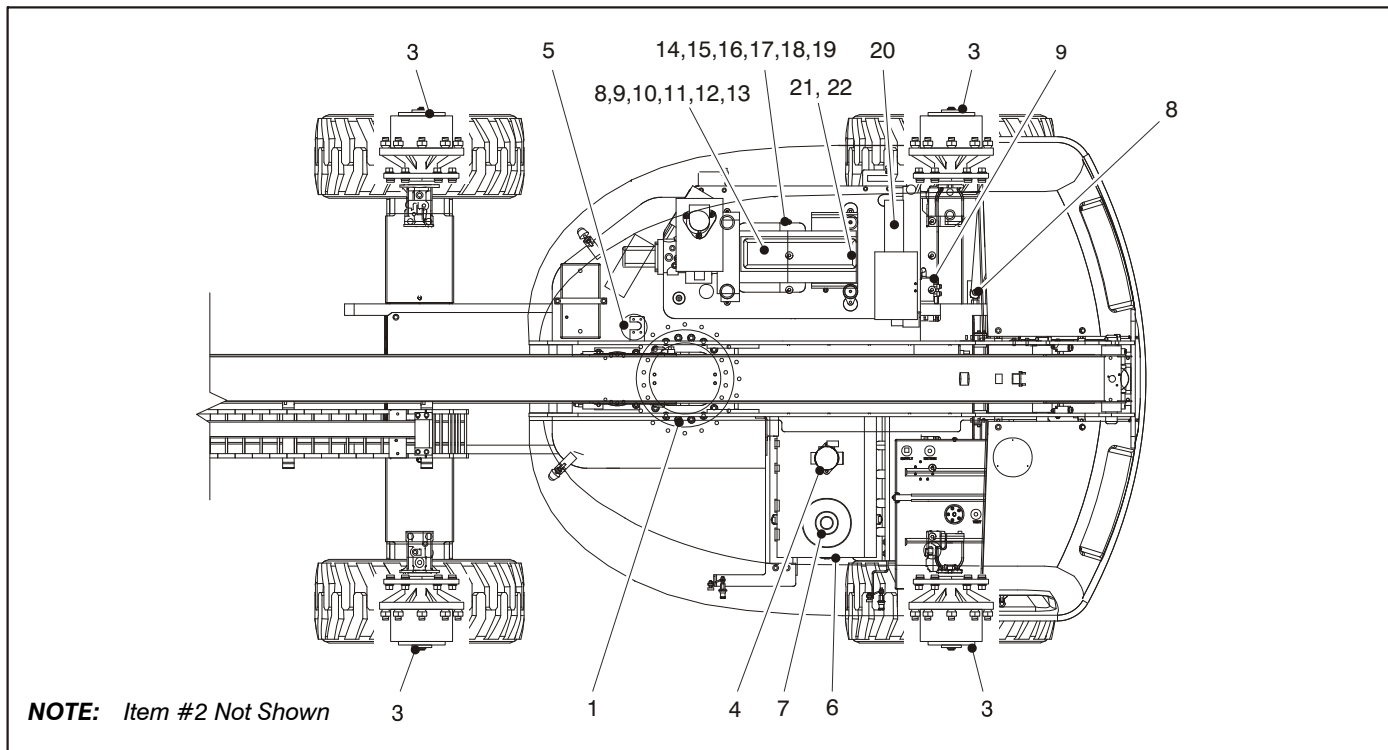

Figure 6-12. Operator Maintenance and Lubrication Diagram

SECTION 6 - GENERAL SPECIFICATIONS & OPERATOR MAINTENANCE

6.3 OPERATOR MAINTENANCE

NOTE: The following numbers correspond to those in Figure 6-12., Operator Maintenance and Lubrication Diagram.

Table 6-20. Lubrication Specifications

KEY	SPECIFICATIONS
MPG	Multipurpose Grease having a minimum dripping point of 350° F (177° C). Excellent water resistance and adhesive qualities, and being of extreme pressure type. (Timken OK 40 pounds minimum.)
EPGL	Extreme Pressure Gear Lube (oil) meeting API service classification GL-5 or MIL-Spec MIL-L-2105
HO	Hydraulic Oil. API service classification GL-3, e.g. Mobilfluid 424.
EO	Engine (crankcase) Oil. Gas - API SF, SH, SG class, MIL-L-2104. Diesel - API CC/CD class, MIL-L-2104B/MIL-L-2104C.
OGL	Open Gear Lubricant - Mobiltac 375 or equivalent.

NOTICE

LUBRICATION INTERVALS ARE BASED ON MACHINE OPERATION UNDER NORMAL CONDITIONS. FOR MACHINES USED IN MULTI-SHIFT OPERATIONS AND/OR EXPOSED TO HOSTILE ENVIRONMENTS OR CONDITIONS, LUBRICATION FREQUENCIES MUST BE INCREASED ACCORDINGLY.

NOTE: It is recommended as a good practice to replace all filters at the same time.

1. Swing Bearing - Internal Ball Bearing

Lube Point(s) - 2 Grease Fittings

Capacity - A/R

Lube - MPG

Interval - Every 3 months or 150 hrs of operation

Comments - Fittings in center of bearing: Remote

Access is optional

2. Wheel Bearings (2WD Only)

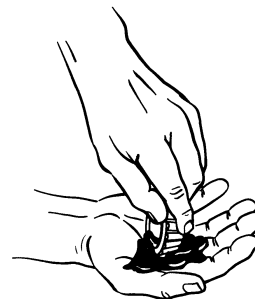

Lube Point(s) - Repack

Capacity - A/R

Lube - MPG

Interval - Every 2 years or 1200 hours of operation

SECTION 6 - GENERAL SPECIFICATIONS & OPERATOR MAINTENANCE

3. Wheel Drive Hub

Lube Point(s) - Level/Fill Plug

Capacity - 17 oz. (0.5 L) - 1/2 Full

Lube - EPGL

Interval - Check level every 3 months or 150 hrs of operation; change every 2 years or 1200 hours of operation

4. Hydraulic Return Filter



Interval - Change after first 50 hrs. and every 6 months or 300 hrs. thereafter or whenever Charge Filter is replaced.

5. Hydraulic Charge Filter



Interval - Change after first 50 hrs. and every 6 months or 300 hrs. thereafter or as indicated by Condition Indicator.

6. Hydraulic Tank

Lube Point(s) - Fill Cap

Capacity - 40.0 gal. tank (151L) 52.0 gal. system (196.8L)

Lube - HO

Interval - Check Level daily; Change every 2 years or 1200 hours of operation.

SECTION 6 - GENERAL SPECIFICATIONS & OPERATOR MAINTENANCE

7. Suction Strainers

Lube Point(s) - 2

Interval - Every 2 years or 1200 hours of operation, remove and clean at time of hydraulic oil change.

8. Oil Change w/Filter - Ford

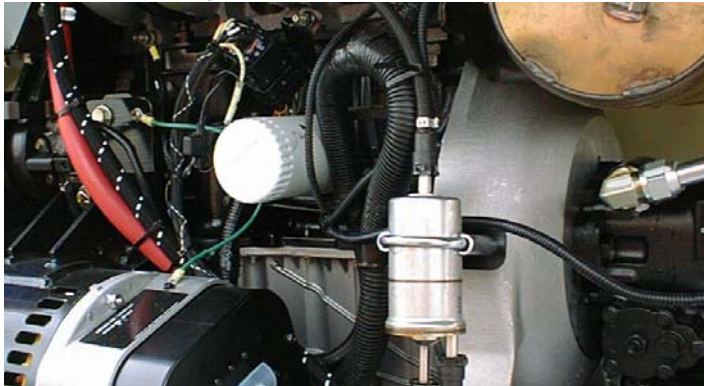

Lube Point(s) - Fill Cap/Spin-on Element (JLG P/N 7014501)

Capacity - 4.5 qt. (4.25 L)

Lube - EO

Interval - 3 Months or 150 hours of operation

Comments - Check level daily/Change in accordance with engine manual.

9. Oil Change w/Filter - Deutz

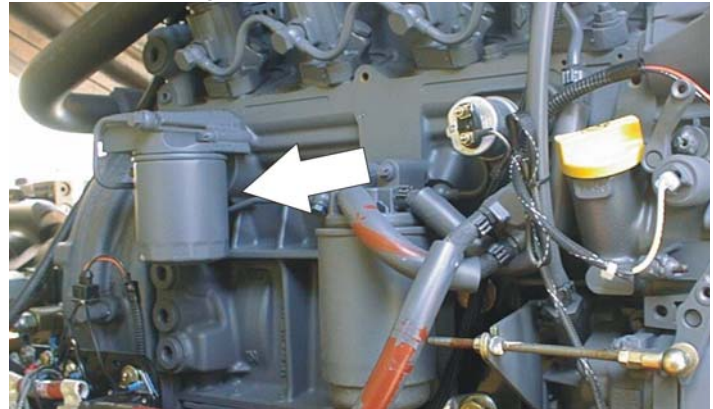

Lube Point(s) - Fill Cap/Spin-on Element (JLG P/N 7016331)

Capacity - 6.3 qt. (5.9 L) engine only

Lube - EO

Interval - Every Year or 1200 hours of operation

Comments - Check level daily/Change in accordance with engine manual.

SECTION 6 - GENERAL SPECIFICATIONS & OPERATOR MAINTENANCE

10. Oil Change w/Filter - Isuzu

Lube Point(s) - Fill Cap/Spin-on Element (JLG P/N 7022111)

Capacity - 6 qt. (5.6L) engine; 6.5 qt. (6.1L) w/cooler
Lube - EO

Interval - 3 Months or 150 hours of operation

Comments - Check level daily/Change in accordance with engine manual.

11. Oil Change w/Filter - Caterpillar

Lube Point(s) - Fill Cap/Spin-on Element (JLG P/N 7026855)

Capacity - 10 qt. (9.4 L)
Lube - EO

Interval - Every Year or 500 hours of operation

Comments - Check level daily/Change in accordance with engine manual.

12. Oil Change w/Filter - GM

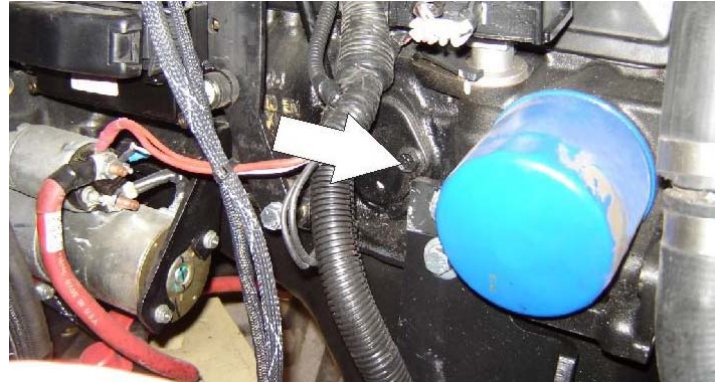

Lube Point(s) - Fill Cap/Spin-on Element (JLG P/N 7027965)

Capacity - 4.5 qt. (4.25 L) w/filter
Lube - EO

Interval - 3 Months or 150 hours of operation

Comments - Check level daily/Change in accordance with engine manual.

SECTION 6 - GENERAL SPECIFICATIONS & OPERATOR MAINTENANCE

13. Oil Change w/Filter - Perkins

Lube Point(s) - Fill Cap/Spin-on Element (JLG P/N 7026855)

Capacity - 10 qt. (9.4 L)

Lube - EO

Interval - Every Year or 500 hours of operation

Comments - Check level daily/Change in accordance with engine manual.

14. Fuel Filter - Ford

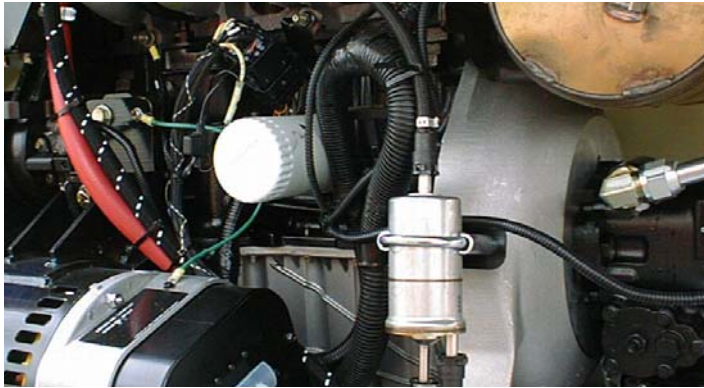

Lube Point(s) - Replaceable Element
Interval - Every Year or 600 hours of operation

15. Fuel Filter - Deutz

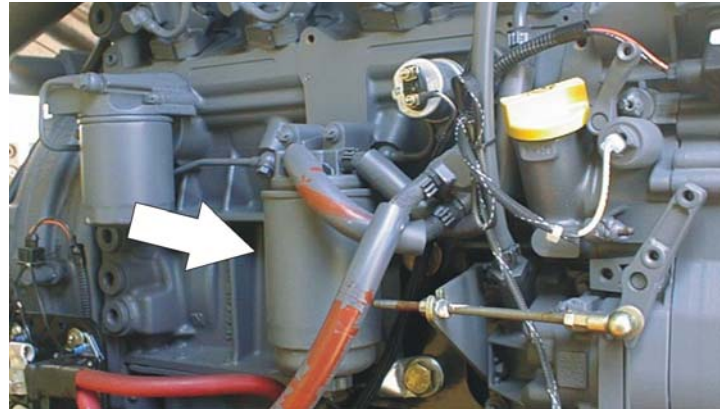

Lube Point(s) - Replaceable Element
Interval - Every Year or 600 hours of operation

16. Fuel Filter - Isuzu

Lube Point(s) - Replaceable Element
Interval - Every Year or 600 hours of operation

17. Fuel Filter - Caterpillar

Lube Point(s) - Replaceable Element
Interval - Every Year or 600 hours of operation

SECTION 6 - GENERAL SPECIFICATIONS & OPERATOR MAINTENANCE

18. Fuel Filter (Gasoline) - GM

Lube Point(s) - Replaceable Element

Interval - Every 6 months or 300 hours of operation

19. Fuel Filter - Perkins

Lube Point(s) - Replaceable Element

Interval - Every Year or 600 hours of operation

20. Air Filter



Lube Point(s) - Replaceable Element

Interval - Every 6 months or 300 hours of operation or as indicated by the condition indicator

21. Electronic Pressure Regulator (LP only)

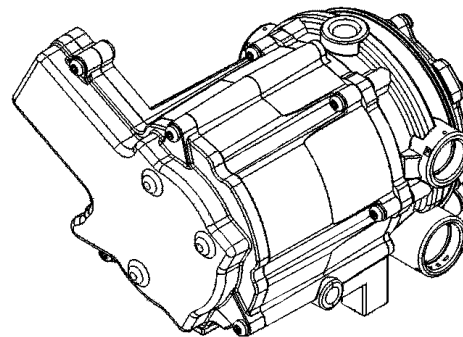

Interval - 3 Months or 150 hours of operation

Comments - Drain oil build up. Refer to Section 6.5, DRAINING OIL BUILD UP FROM THE PROPANE REGULATOR (Prior to S/N 0300109274)

22. Fuel Filter (Propane) - GM Engine

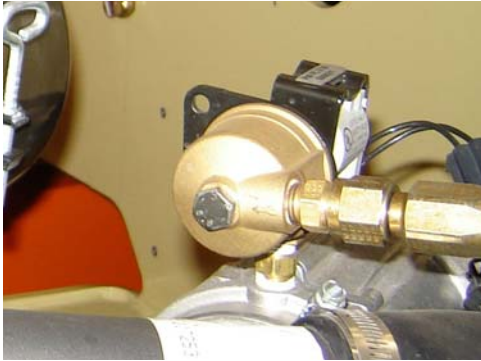

Interval - 3 Months or 150 hours of operation

Comments - Replace filter. Refer to Section 6.6, Propane Fuel Filter Replacement

6.4 TIRES & WHEELS

Tire Inflation

The air pressure for pneumatic tires must be equal to the air pressure that is stenciled on the side of the JLG product or rim decal for safe and proper operational characteristics.

Tire Damage

For pneumatic tires, JLG Industries, Inc. recommends that when any cut, rip, or tear is discovered that exposes sidewall or tread area cords in the tire, measures must be taken to remove the JLG product from service immediately. Arrangements must be made for replacement of the tire or tire assembly.

For polyurethane foam filled tires, JLG Industries, Inc. recommends that when any of the following are discovered, measures must be taken to remove the JLG product from service immediately and arrangements must be made for replacement of the tire or tire assembly.

- a smooth, even cut through the cord plies which exceeds 3 inches (7.5 cm) in total length
- any tears or rips (ragged edges) in the cord plies which exceeds 1 inch (2.5 cm) in any direction
- any punctures which exceed 1 inch in diameter

SECTION 6 - GENERAL SPECIFICATIONS & OPERATOR MAINTENANCE

- any damage to the bead area cords of the tire

If a tire is damaged but is within the above noted criteria, the tire must be inspected on a daily basis to insure the damage has not propagated beyond the allowable criteria.

Tire Replacement

JLG recommends a replacement tire be the same size, ply and brand as originally installed on the machine. Please refer to the JLG Parts Manual for the part number of the approved tires for a particular machine model. If not using a JLG approved replacement tire, we recommend that replacement tires have the following characteristics:

- Equal or greater ply/load rating and size of original
- Tire tread contact width equal or greater than original
- Wheel diameter, width, and offset dimensions equal to the original
- Approved for the application by the tire manufacturer (including inflation pressure and maximum tire load)

Unless specifically approved by JLG Industries Inc. do not replace a foam filled or ballast filled tire assembly with a pneumatic tire. When selecting and installing a replacement tire, ensure that all tires are inflated to the pressure recommended by JLG. Due to size variations between tire brands, both tires on the same axle should be the same.

Wheel Replacement

The rims installed on each product model have been designed for stability requirements which consist of track width, tire pressure, and load capacity. Size changes such as rim width, center piece location, larger or smaller diameter, etc., without written factory recommendations, may result in an unsafe condition regarding stability.

Wheel Installation

It is extremely important to apply and maintain proper wheel mounting torque.

⚠ WARNING

WHEEL NUTS MUST BE INSTALLED AND MAINTAINED AT THE PROPER TORQUE TO PREVENT LOOSE WHEELS, BROKEN STUDS, AND POSSIBLE DANGEROUS SEPARATION OF WHEEL FROM THE AXLE. BE SURE TO USE ONLY THE NUTS MATCHED TO THE CONE ANGLE OF THE WHEEL.

Tighten the lug nuts to the proper torque to prevent wheels from coming loose. Use a torque wrench to tighten the fasteners. If you do not have a torque wrench, tighten the fasteners with a lug wrench, then immediately have a service garage or dealer tighten the lug nuts to the proper torque. Over-tightening will result in breaking the studs or permanently deforming the mounting stud holes in the wheels. The proper procedure for attaching wheels is as follows:

1. Start all nuts by hand to prevent cross threading. DO NOT use a lubricant on threads or nuts.

2. Tighten nuts in the following sequence:

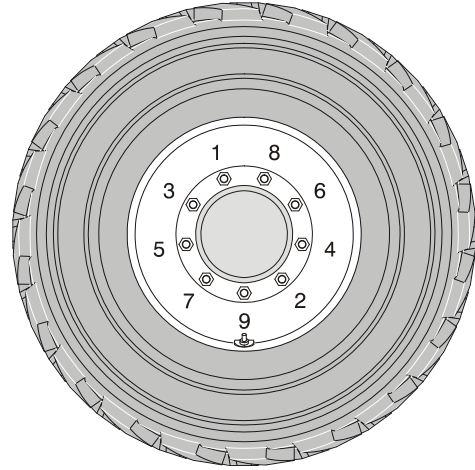

- The tightening of the nuts should be done in stages. Following the recommended sequence, tighten nuts per wheel torque chart.

Table 6-21. Wheel Torque Chart

TORQUE SEQUENCE		
1st Stage	2nd Stage	3rd Stage
40 ft. lbs. (55 Nm)	100 ft. lbs. (130 Nm)	170 ft. lbs. (255 Nm)

- Wheel nuts should be torqued after first 50 hours of operation and after each wheel removal. Check torque every 3 months or 150 hours of operation.

6.5 DRAINING OIL BUILD UP FROM THE PROPANE REGULATOR (PRIOR TO S/N 0300109274)

During the course of normal operation oils may build inside the primary and secondary chambers of the propane pressure regulator. These oils may be a result of poor fuel quality, contamination of the fuel supply chain, or regional variation in the make up of the fuel. If the build up of the oil is significant this can effect the operation of the fuel control system. Refer to Section 6.3, Operator Maintenance for maintenance intervals. More frequent draining may be required if the fuel supply has been contaminated.

NOTICE

FOR BEST RESULTS WARM THE ENGINE TO OPERATING TEMPERATURE BEFORE DRAINING. THIS WILL ALLOW THE OILS TO FLOW FREELY FROM THE REGULATOR.

- Move the equipment to a well ventilated area. Ensure there are no external ignition sources.
- Start the engine and bring to operating temperature.
- With the engine running, close the manual tank valve and run the engine out of fuel.

SECTION 6 - GENERAL SPECIFICATIONS & OPERATOR MAINTENANCE

4. Push in the Emergency Switch once the engine stops.
5. Disconnect the electrical connection to the LPG fuel temperature sensor in the auxiliary fuel port of the EPR.

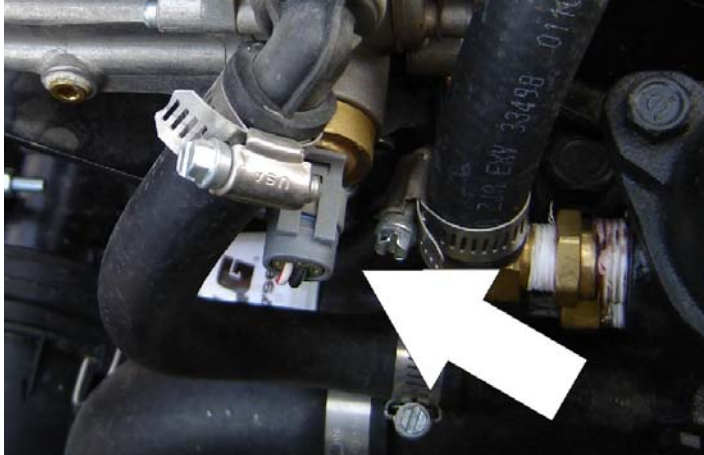

6. Remove the retainer clip for the LPG fuel temperature sensor and remove the sensor from the regulator body.

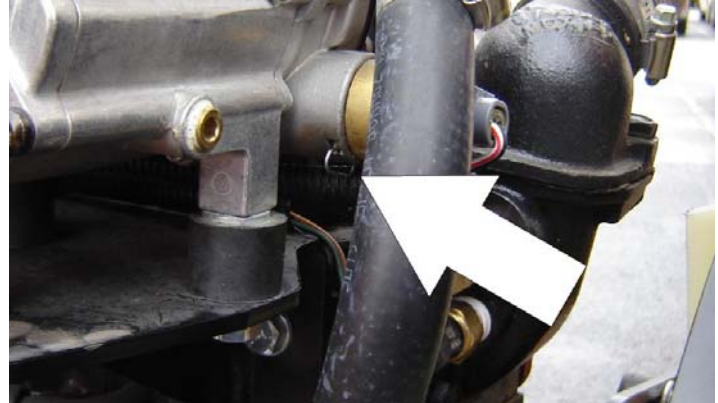

NOTE: Have a small container ready to collect oil that will drain freely from the regulator at this point.

7. Once all of the oil has been drained, reinstall the LPG fuel temperature sensor and reconnect the electrical connector.
8. Open the fuel tank manual valve.
9. Start the engine and verify all connections are secure.
10. Dispose of any drained oil per local regulations in a safe and proper fashion.

6.6 PROPANE FUEL FILTER REPLACEMENT

Installation

Removal

1. Relieve the propane fuel system pressure. Refer to Propane Fuel System Pressure Relief.
2. Disconnect the negative battery cable.
3. Slowly loosen the Filter housing and remove it.
4. Pull the filter housing from the Electric lock off assembly.
5. Remove the filter from the housing.
6. Locate Filter magnet and remove it.
7. Remove and discard the housing seal.
8. Remove and discard the retaining bolt seal.
9. Remove and discard mounting plate to lock off O-ring seal.

NOTICE

BE SURE TO REINSTALL THE FILTER MAGNET INTO THE HOUSING BEFORE INSTALLING NEW SEAL

1. Install the mounting plate to lock off O-ring seal.
2. Install the retaining bolt seal (if equipped).
3. Install the housing seal.
4. Drop the magnet into the bottom of the filter housing.
5. Install the filter into the housing.
6. If equipped, install the retaining bolt into the filter housing.
7. Install the filter up to the bottom of the electric lock off.
8. Tighten the filter to 106 in lbs (12 Nm).
9. Open manual shut-off valve. Start the vehicle and leak check the propane fuel system at each serviced fitting. Refer to Propane Fuel System Leak Test.

SECTION 6 - GENERAL SPECIFICATIONS & OPERATOR MAINTENANCE

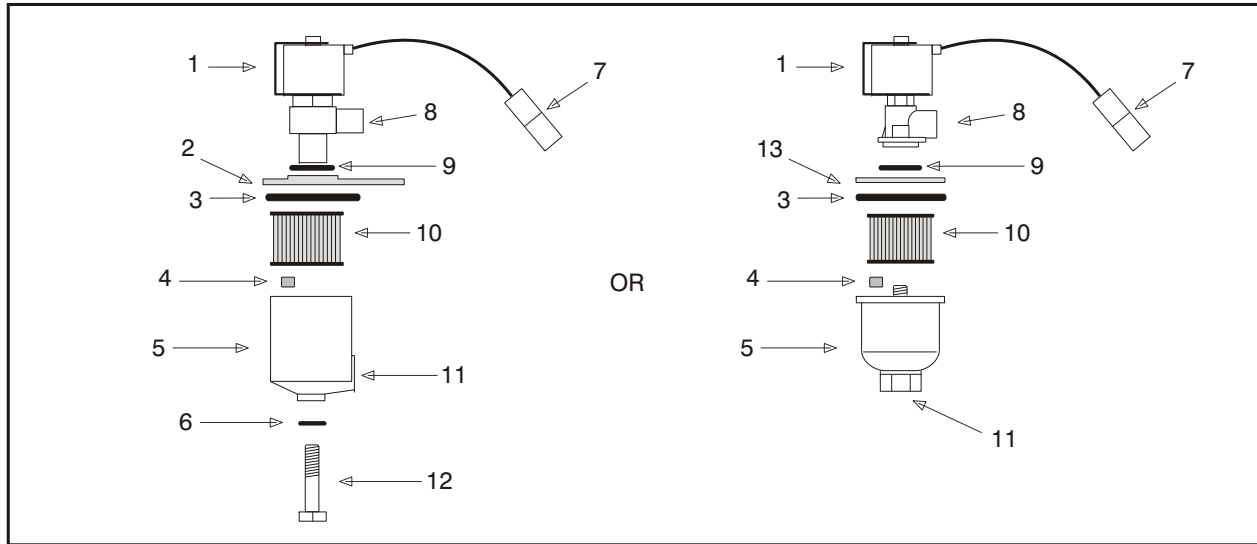

- | | | |
|-------------------------------|-------------------------|--------------------|
| 1. Electric Lock Off Solenoid | 6. Seal | 10. Filter |
| 2. Mounting Plate | 7. Electrical Connector | 11. Fuel Inlet |
| 3. Housing Seal | 8. Fuel Outlet | 12. Retaining Bolt |
| 4. Filter Magnet | 9. O-ring | 13. Ring |
| 5. Filter Housing | | |

Figure 6-13. Filter Lock Assembly

6.7 PROPANE FUEL SYSTEM PRESSURE RELIEF 6.8 SUPPLEMENTAL INFORMATION

CAUTION

THE PROPANE FUEL SYSTEM OPERATES AT PRESSURES UP TO 312 PSI (21.5 BAR). TO MINIMIZE THE RISK OF FIRE AND PERSONAL INJURY, RELIEVE THE PROPANE FUEL SYSTEM PRESSURE (WHERE APPLICABLE) BEFORE SERVICING THE PROPANE FUEL SYSTEM COMPONENTS.

To relieve propane fuel system pressure:

1. Close the manual shut-off valve on the propane fuel tank.
2. Start and run the vehicle until the engine stalls.
3. Turn the ignition switch OFF.

CAUTION

RESIDUAL VAPOR PRESSURE WILL BE PRESENT IN THE FUEL SYSTEM. ENSURE THE WORK AREA IS WELL VENTILATED BEFORE DISCONNECTING ANY FUEL LINE.

The following information is provided in accordance with the requirements of the European Machinery Directive 2006/42/EC and is only applicable to CE machines.

For electric powered machines, the equivalent continuous A-Weighted sound pressure level at the work platform is less than 70dB(A)

For combustion engine powered machines, guaranteed Sound Power Level (LWA) per European Directive 2000/14/EC (Noise Emission in the Environment by Equipment for Use Outdoors) based on test methods in accordance with Annex III, Part B, Method 1 and 0 of the directive, is 104 dB.

The vibration total value to which the hand-arm system is subjected does not exceed $2,5 \text{ m/s}^2$. The highest root mean square value of weighted acceleration to which the whole body is subjected does not exceed $0,5 \text{ m/s}^2$.

SECTION 7. INSPECTION AND REPAIR LOG

Machine Serial Number _____

Table 7-1. Inspection and Repair Log

Date	Comments

SECTION 7 - INSPECTION AND REPAIR LOG

Table 7-1. Inspection and Repair Log

Date	Comments



An Oshkosh Corporation Company

TRANSFER OF OWNERSHIP

To Product Owner:

If you now own but ARE NOT the original purchaser of the product covered by this manual, we would like to know who you are. For the purpose of receiving safety-related bulletins, it is very important to keep JLG Industries, Inc. updated with the current ownership of all JLG products. JLG maintains owner information for each JLG product and uses this information in cases where owner notification is necessary.

Please use this form to provide JLG with updated information with regard to the current ownership of JLG products. Please return completed form to the JLG Product Safety & Reliability Department via facsimile or mail to address as specified below.

Thank You,

Product Safety & Reliability Department
JLG Industries, Inc.

13224 Fountainhead Plaza
Hagerstown, MD 21742
USA

Telephone: +1-717-485-6591
Fax: +1-301-745-3713

NOTE: Leased or rented units should not be included on this form.

Mfg. Model: _____

Serial Number: _____

Previous Owner: _____

Address: _____

Country: _____ Telephone: (____) _____

Date of Transfer: _____

Current Owner: _____

Address: _____

Country: _____ Telephone: (____) _____

Who in your organization should we notify?

Name: _____

Title: _____



WARNING:



The engine exhaust from this product contains chemicals known to the State of California to cause cancer, birth defects, or other reproductive harm.

1702961

PROPOSITION 65 WARNING

- **Battery posts, terminals and related accessories contain lead and lead compounds, chemicals known to the State of California to cause cancer and reproductive harm.**
- **Batteries also contain other chemicals known to the State of California to cause cancer.**
- **Wash hands after handling.**



An Oshkosh Corporation Company

Corporate Office
JLG Industries, Inc.
1 JLG Drive
McConnellsburg PA. 17233-9533
USA

(717) 485-5161

(717) 485-6417



3121216

JLG Worldwide Locations

JLG Industries (Australia)
P.O. Box 5119
11 Bolwarra Road
Port Macquarie
N.S.W. 2444
Australia

+61 2 65 811111

+61 2 65813058

JLG Latino Americana Ltda.
Rua Eng. Carlos Stevenson,
80-Suite 71
13092-310 Campinas-SP
Brazil

+55 19 3295 0407

+55 19 3295 1025

JLG Industries (UK) Ltd
Bentley House
Bentley Avenue
Middleton
Greater Manchester
M24 2GP - England

+44 (0)161 654 1000

+44 (0)161 654 1001

JLG France SAS
Z.I. de Baulieu
47400 Fauillet
France

+33 (0)5 53 88 31 70

+33 (0)5 53 88 31 79

JLG Deutschland GmbH
Max-Planck-Str. 21
D - 27721 Ritterhude - Ihlpohl
Germany

+49 (0)421 69 350 20

+49 (0)421 69 350 45

JLG Equipment Services Ltd.
Rm 1107 Landmark North
39 Lung Sum Avenue
Sheung Shui N. T.
Hong Kong

(852) 2639 5783

(852) 2639 5797

JLG Industries (Italia) s.r.l.
Via Po. 22
20010 Pregnana Milanese - MI
Italy

+39 029 359 5210

+39 029 359 5845

Oshkosh-JLG Singapore Technology
Equipment Pte Ltd
29 Tuas Ave 4,
Jurong Industrial Estate
Singapore, 639379

+65-6591 9030

+65-6591 9031

Plataformas Elevadoras
JLG Iberica, S.L.
Trapadella, 2
P.I. Castellbisbal Sur
08755 Castellbisbal, Barcelona
Spain

+34 93 772 4700

+34 93 771 1762

JLG Sverige AB
Enkopingsvagen 150
Box 704
SE - 176 27 Jarfalla
Sweden

+46 (0)850 659 500

+46 (0)850 659 534